

YOU GOT TO GRANT IT TO GRANSA



SUBMERSIBLE PUMPS  
AND MOTORS- **50Hz**

# COMPANY PROFILE



## YOU GOT TO GRANT IT TO GRANSA

First things first. Gransa is not your run-of-the-mill pump. It is the best there is. Period. In fact it is much more than just pumps. It is a movement. A revolution that can bring about change in the way we look at pumping technology. Gransa incorporates inspired design with new generation technology to ensure perfection at every level. Aesthetically pleasing with its sleek hi-tech looks, every Gransa pump is a marvel of workmanship and design and technologically superior. Functionally, Gransa is in a class all its own. The performance parameters are legendary and would leave you awe struck. It is not for nothing that it is said: you got to grant it to Gransa!

The Gransa quality edge comes from our collective attitude that will not compromise, will not accept second best, will not take no for an answer and will not rest until the perfect solution is found. Every single product bears the imprint of this commitment. Right from sourcing raw material to the finished product every step is monitored both online and offline till it meets our



exacting standards. We know that there is a lot riding on the quality of the raw material used in the manufacture of the pump. That is why we invest more time and money in sourcing the finest raw material available to give you a pump that is perfect in all respects. Another area where our pumps score is in energy efficiency. In these days of depleting energy resources, we believe that it is imperative that power saving should be central to your buying decision.

The fact that the manufacturing facilities are quite extensive and state of the art makes a big difference. The infrastructure is one of the best in the world - CI foundry, fully mechanized and Steel automated Foundry, world class R&D facilities with flow dynamic software, ISO 9001 & 14001 Certified production environment, highly skilled and qualified hands and more. All contributing to a production capacity of over 1 million pumps per annum.

The range is extensive. Applications include irrigation, domestic, civil construction, de-watering, Fire fighting, HVAC, Industrial etc. Our 4" to 8" borehole submersible pumps meet NEMA standards.

Gransa, in keeping with its reputation as a global brand has a wide network across strategic locations worldwide with an extensive dealer presence and service support centers.



# C O N T E N T S

Page No .

---

## WATER FILLED SUBMERSIBLE MOTORS - REWINDABLE

Cross Sectional Drawings 4" to 10"	6 - 11
Specifications - 4" Motors	12
Technical Data - 4" Motors	13

---

Specifications - 6" Motors	14
Technical Data - 6" Motors	15-17

---

Specifications - 8" Motors	18
Technical Data - 8" Motors	19

---

Specifications - 10" Motors	20
Technical Data - 10" Motors	21

---

## OIL FILLED SUBMERSIBLE MOTORS

Cross Sectional Drawing - 4" Motors	23
Specifications - 4" Motors	24
Technical Data - 4" Motors	25

---

Specifications - 6" Motors	26
Technical Data - 6" Motors	27

---

## RESIN FILLED SUBMERSIBLE MOTORS

Specifications - 4" Motors	29
Technical Data - 4" Motors	30

---

Specifications - 4" Motors	31
Technical Data - 4" Motors	32
Cable Selection	33-34

---

## BOREWELL SUBMERSIBLE PUMPS

General Information	35
Types of Construction	38
Cross Sectional Drawings - GP, GS Series	39-48

---

## GP SERIES

Material of Construction	50
Performance Curves 3" Pumps	51
Height & Weight Table 3" Pumps	52
Performance Curves 4" Pumps	53-61
Height & Weight Table 4" Pumps	62-63

---

## GS SERIES

Performance Curves 4" Pumps	64-69
Height & Weight Table 4" Pumps	70-71
Performance Curves 6" Pumps	72-87
Height & Weight Table 6" Pumps	88-92
Performance Curves 8" Pumps	93-96
Height & Weight Table 8" Pumps	97
Performance Curves 10" Pumps	98-103
Height & Weight Table 10" Pumps	104-105

# WATER FILLED SUBMERSIBLE MOTORS - REWINDABLE

## WATER FILLED MOTORS

Gransa GW Series motor are Rewindable Water Cooled type motor's stators are wound with film insulated copper wires. The motors are provided with water lubricated journal and thrust bearings to minimize the friction. The motor must be filled with clear cold fresh water mixed with propylene glycol before commissioning. All rotating parts are dynamically balanced to ensure the bearing life. The pressure equalizing diaphragm is provided to balance the pressure & volume variation due to thermal expansion inside the motors. All single phase motors are fitted with thermal overload protector. All mounting dimensions of these motors are in accordance with NEMA standard.



### Features :

- | High operating efficiency
- | Water cooled Re-windable motor
- | Can be easily dismantled and repaired
- | Extremely hardwearing and water lubricated bearings
- | Specially designed thrust bearing to withstand high axial loads.
- | AISI 630 (17.4 PH) motor shaft extension for longer life.

### Applications :

- | Residential
- | Irrigation
- | Fountains
- | Pressure Boosting units
- | Gardens
- | Sprinkler Systems
- | Oil & Gas
- | De-watering



# GENERAL INFORMATION

## IDENTIFICATION

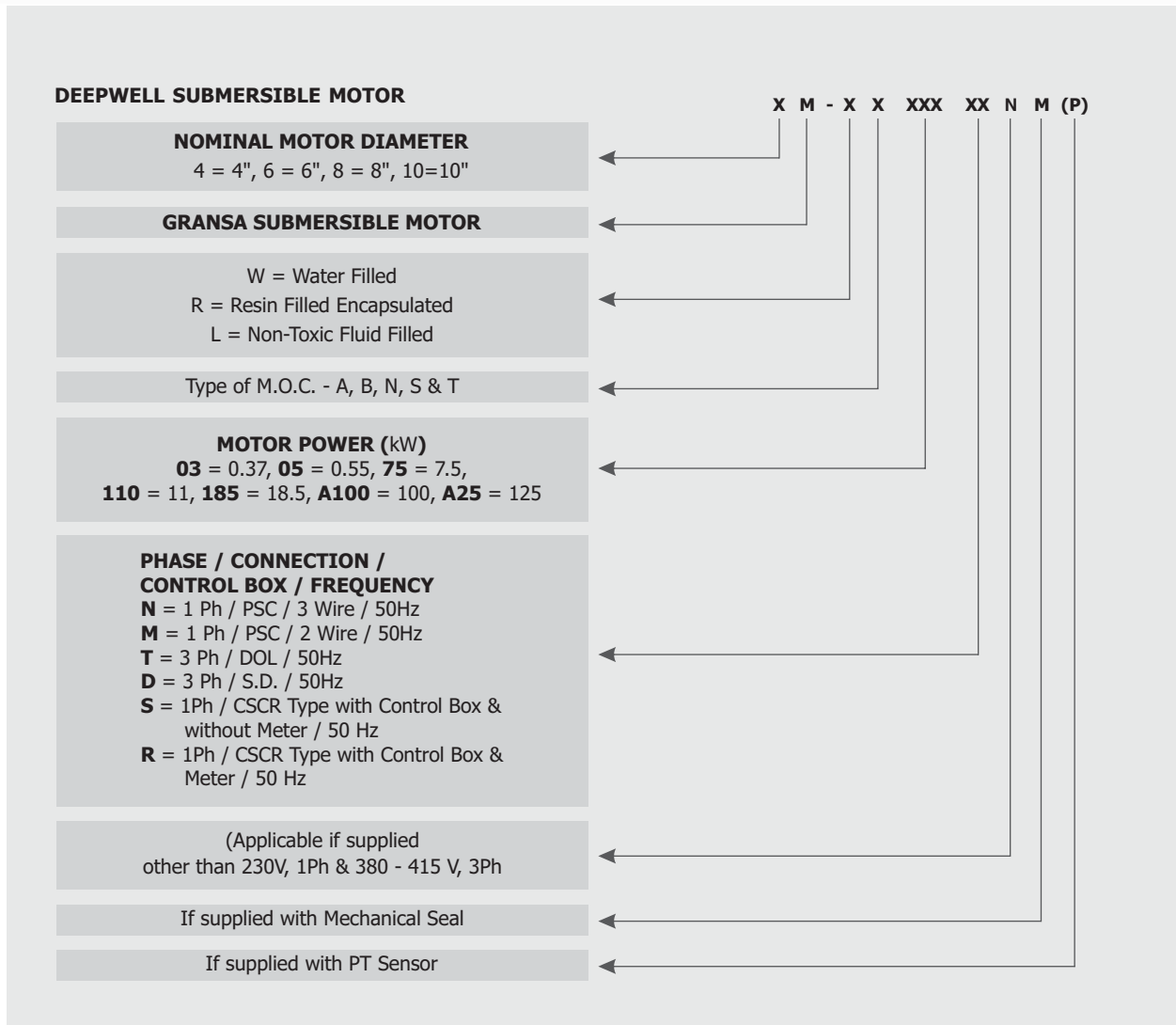

# WATER FILLED SUBMERSIBLE MOTORS - REWINDABLE

Nominal Diameter : 4"

## CROSS SECTIONAL DRAWING

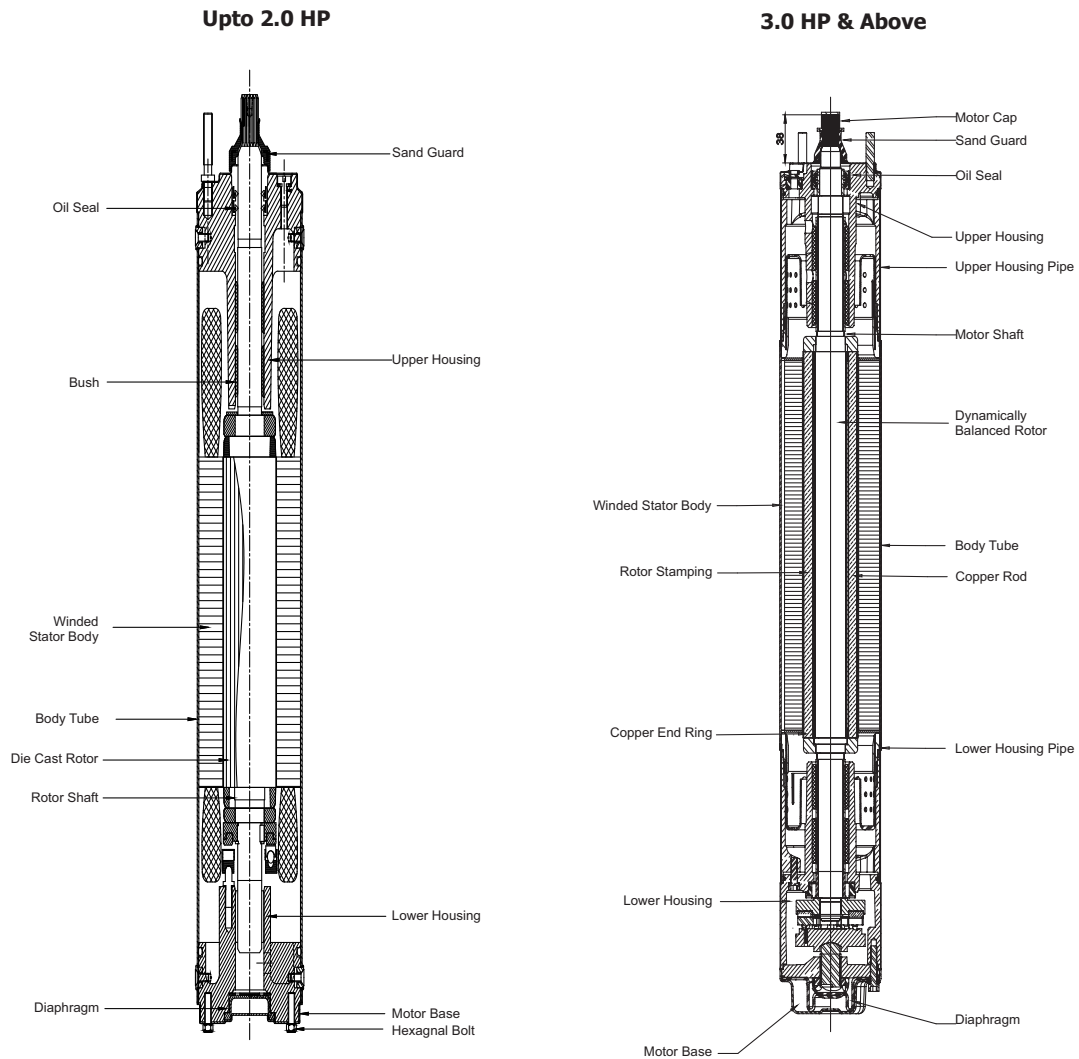

## MATERIALS OF CONSTRUCTION

Part Name	Type - A	Type - N
Shaft Seal	Nitrile Rubber (NBR)	Nitrile Rubber (NBR)
Housing Shell	SS - 304	SS - 316
Stator Shell	SS - 304 / 441	SS - 316
Thrust Pad	Carbon Graphite	Carbon Graphite
Thrust Bearing	SS - 420	SS - 420
Diaphragm	High Nitrile Rubber	High Nitrile Rubber
Motor Base	SS - 304	SS - 316
Bush	LTB	LTB



# WATER FILLED SUBMERSIBLE MOTORS - REWINDABLE

Nominal Diameter : 6"

## CROSS SECTIONAL DRAWING

### 6" 138 MOTOR

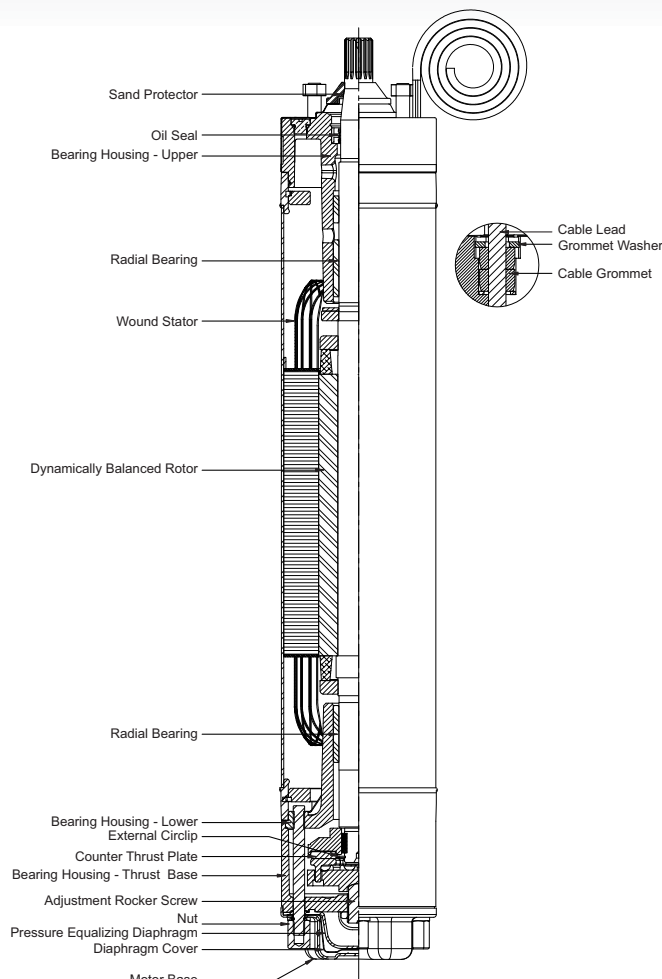

The Company reserves the right to modify the Technical Specifications & Illustrations without prior notice

## MATERIALS OF CONSTRUCTION

Part Name	Type - A	Type - N	Type - B	Type - S	Type - T
Shaft Seal / Mechanical Seal	Nitrile Rubber (NBR) / Ceramic - Carbon	Nitrile Rubber (NBR) / Ceramic - Carbon	Nitrile Rubber (NBR) / Ceramic - Carbon	Nitrile Rubber (NBR) / Ceramic - Carbon	Nitrile Rubber (NBR) / Ceramic - Carbon
Upper & Lower Housings	Cast Iron	Cast Iron	Cast Iron	Casted SS - 304	Casted SS - 316
Stator Shell	SS - 304	SS - 316	SS - 304	SS - 304	SS - 316
Thrust Pad	Carbon Graphite	Carbon Graphite	Carbon Graphite	Carbon Graphite	Carbon Graphite
Thrust Bearing	SS - 420	SS - 420	SS - 420	SS - 420	SS - 420
Diaphragm	High Nitrile Rubber	High Nitrile Rubber	High Nitrile Rubber	High Nitrile Rubber	High Nitrile Rubber
Motor Base	SS - 304	SS - 316	Cast Iron	SS - 304	SS - 316
Upper Housing Shell	SS - 304	SS - 316	Nil	Nil	Nil
Shaft	Up to 30 HP : SS-431 35 to 50Hp : EN8	Up to 30 HP : SS-431 35 to 50Hp : EN8	Up to 30 HP : SS-431 35 to 50Hp : EN8	Up to 30 HP : SS-431 35 to 50Hp : EN8	Up to 30 HP : SS-431 35 to 50Hp : EN8
Shaft Extension	Up to 30 HP : SS-431 35 to 50Hp : 17.4 ph	Up to 30 HP : SS-431 35 to 50Hp : 17.4 ph	Up to 30 HP : SS-431 35 to 50Hp : 17.4 ph	Up to 30 HP : SS-431 35 to 50Hp : 17.4 ph	Up to 30 HP : SS-431 35 to 50Hp : 17.4 ph
Sleeves	Up to 30 HP : NA 35 to 50Hp : SS-431	Up to 30 HP : NA 35 to 50Hp : SS-432	Up to 30 HP : NA 35 to 50Hp : SS-433	Up to 30 HP : NA 35 to 50Hp : SS-434	Up to 30 HP : NA 35 to 50Hp : SS-434
Shaft Sleeve	Up to 30 HP : NA 35 to 50Hp : SS-431	Up to 30 HP : NA 35 to 50Hp : SS-431	Up to 30 HP : NA 35 to 50Hp : SS-431	Up to 30 HP : NA 35 to 50Hp : SS-431	Up to 30 HP : NA 35 to 50Hp : SS-431

# WATER FILLED SUBMERSIBLE MOTORS - REWINDABLE

Nominal Diameter : 6"

## CROSS SECTIONAL DRAWING

### 6" FLANGE MOTOR

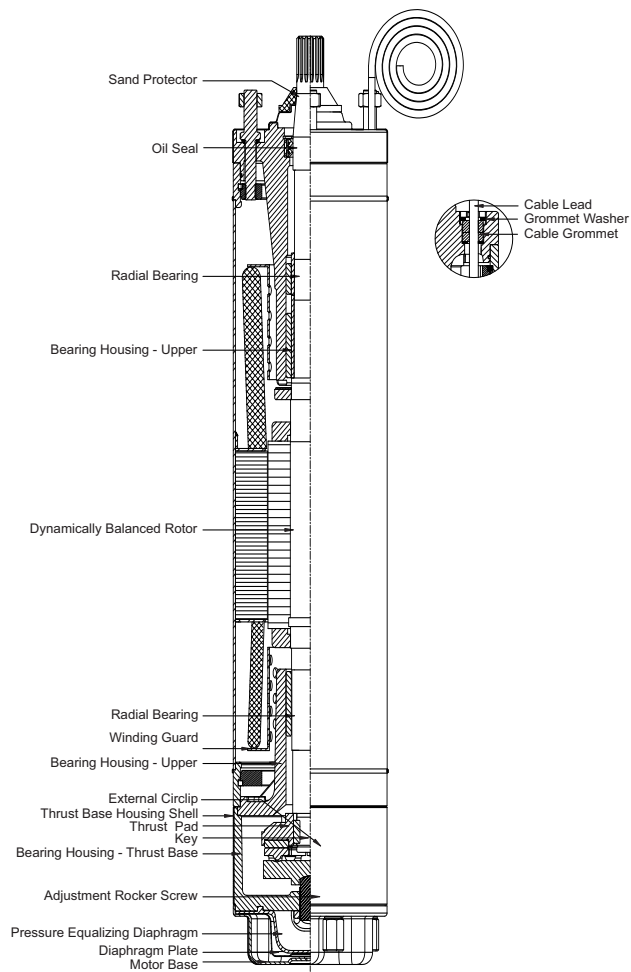

The Company Reserves the right to modify the Technical Specifications & Illustrations without prior notice

# WATER FILLED SUBMERSIBLE MOTORS - REWINDABLE

Nominal Diameter : 6"

## CROSS SECTIONAL DRAWING

### 6" TIE - BOLT TYPE MOTOR

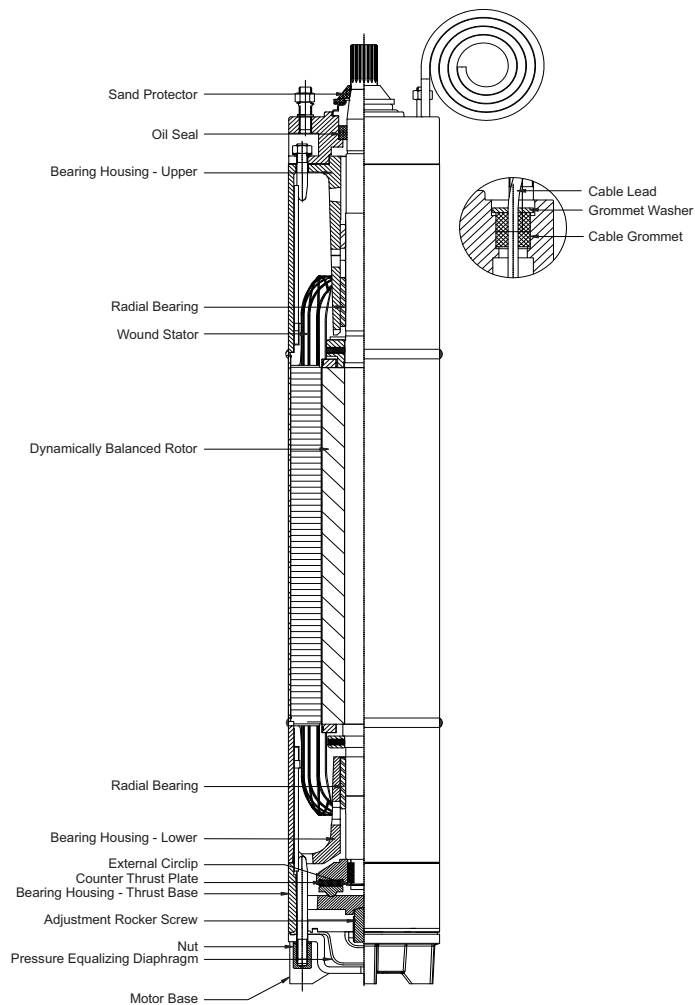

The Company Reserves the right to modify the Technical Specifications & Illustrations without prior notice

# WATER FILLED SUBMERSIBLE MOTORS - REWINDABLE

Nominal Diameter : 8"

## CROSS SECTIONAL DRAWING

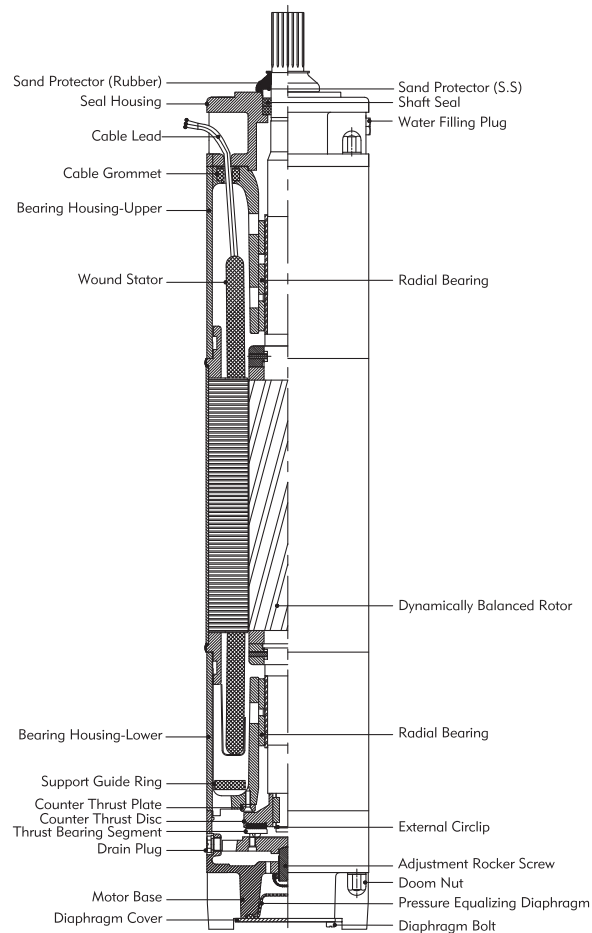

## MATERIALS OF CONSTRUCTION

Part Name	Type - B	Type - S
Shaft Seal Housing	Cast Iron	SS - 304 Casted
Shaft Seal / Mechanical Seal	Nitrile Rubber (NBR) / Ceramic - Carbon, SiC - SiC	Nitrile Rubber (NBR) / Ceramic - Carbon, SiC - SiC
Upper & Lower Housings	Cast Iron	SS - 304 Casted
Stator Shell	SS - 304	SS - 304
Thrust Pad	Carbon Graphite	Carbon Graphite
Thrust Bearing	SS - 420	SS - 420
Diaphragm	High Nitrile Rubber	High Nitrile Rubber
Motor Base	Cast Iron	SS - 304 Casted
Shaft	EN-8	EN-8
Shaft Extension	17.4 Ph	17.4 Ph
Sleeves	SS - 431	SS - 431

# WATER FILLED SUBMERSIBLE MOTORS - REWINDABLE

Nominal Diameter : 10"

## CROSS SECTIONAL DRAWING

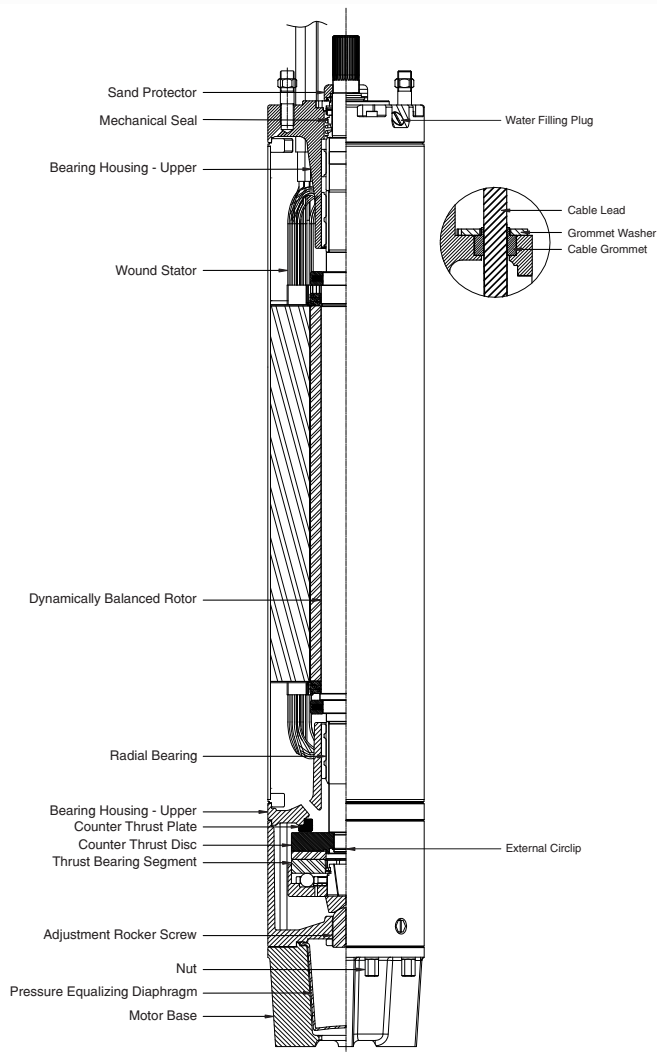

The Company Reserves the right to modify the Technical Specifications & Illustrations without prior notice

## MATERIALS OF CONSTRUCTION

Part Name	Type - A	Type - N	Type - B
Shaft Seal Housing	SS - 304	SS - 316	Cast Iron
Shaft Seal/ Mechanical Seal	Nitrile Rubber (NBR) / Ceramic - Carbon, SiC - SiC	Nitrile Rubber (NBR) / Ceramic - Carbon, SiC - SiC	Nitrile Rubber (NBR) / Ceramic - Carbon, SiC - SiC
Upper & Lower Housings	SS - 304	SS - 316	Cast Iron
Stator Shell	SS - 304	SS - 316	SS - 304
Thrust Pad	Carbon Graphite	Carbon Graphite	Carbon Graphite
Thrust Bearing	SS - 420	SS - 420	SS - 420
Diaphragm	Nitrile Rubber (NBR)	Nitrile Rubber (NBR)	Nitrile Rubber (NBR)
Motor Base	SS - 304	SS - 316	Cast Iron

# WATER FILLED SUBMERSIBLE MOTORS - REWINDABLE

Nominal Diameter : 4"



## SPECIFICATIONS

Power Range	0.37 kW to 2.2 kW - 1 Ph
	0.37 kW to 7.5 kW - 3 Ph
Version	1 Ph - 230 V, 50 Hz, A.C Supply
	3 Ph - 380 V - 415 V, 50 Hz, A.C Supply
Speed	2900 rpm
Insulation Class	Y
Duty Type	S1 (Continuous)
Degree of Protection	IP 58
Down Thrust Load	0.37 kW to 1.5 kW - 3000 N
	2.2 kW to 7.5 kW - 6500 N
Minimum Cooling Flow along the Motor	0.15 m/sec
Maximum Liquid Temperature	33°C
Starts per Hour	20 Times
Mounting Standard	NEMA Standard
Method of Starting	1 Ph - Capacitor Start Capacitor Run (CSCR)
	3 Ph - Direct On Line (DOL)

# WATER FILLED SUBMERSIBLE MOTORS - REWINDABLE

Nominal Diameter : 4"

## TECHNICAL DATA

UPTO 1.5 kW

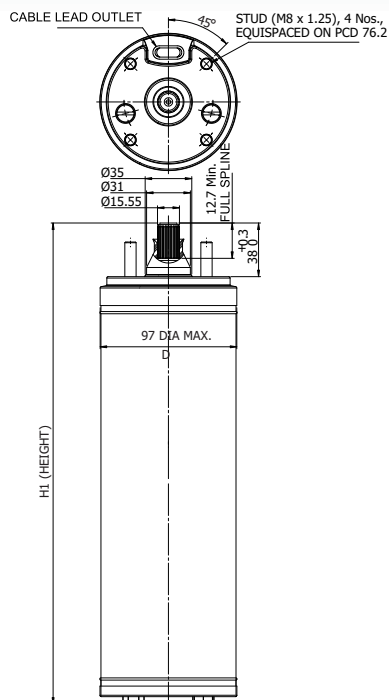

### 4" 1Ph 230V 3 WIRE MOTORS

Model	Motor Power		Full Load Max.(A)	Starting Current (A)	Full load		Max. Down Thrust Load (N)	Starting Torque (Nm)	Torque (Nm)
	kW	HP			Eff. %	Power Factor			
4MWA-03S	0.37	0.5	5	16	39	0.89	3000	2	1.2
4MWA-05S	0.55	0.75	6	21	52	0.9	3000	2.9	1.8
4MWA-07S	0.75	1	7.5	26	54	0.9	3000	4.1	2.5
4MWA-11S	1.1	1.5	10	40	57	0.95	3000	6.1	3.7
4MWA-15S	1.5	2	12	48	60	0.95	3000	8.3	4.9
4MWA-22S	2.2	3	16.5	66	62	0.95	6500	13.3	7.4

### DIMENSIONS AND WEIGHT

Model	Height in (mm)	Nett Weight in Kg
4MWA-03S	410	11.6
4MWA-05S	430	12.6
4MWA-07S	455	13.8
4MWA-11S	495	15.7
4MWA-15S	545	17.7
4MWA-22S	845	33.4

2.2 kW & above

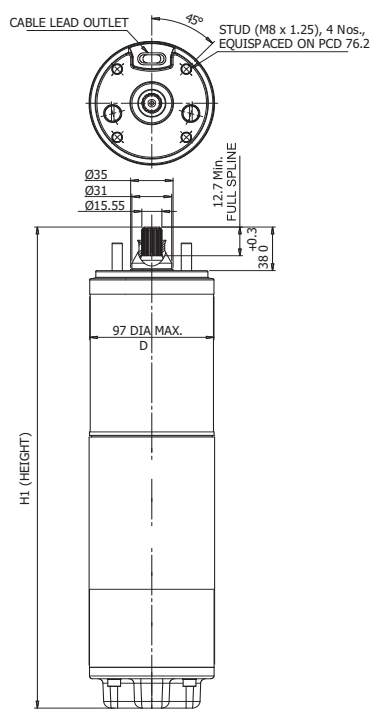

### 4" 3Ph 380-415V D.O.L MOTORS

Model	Motor Power		Full Load Max.(A)	Starting Current (A)	Full load		Max. Down Thrust Load (N)	Starting Torque (Nm)	Torque (Nm)
	kW	HP			Eff. %	Power Factor			
4MWA-03T	0.37	0.5	1.8	5	48	0.75	3000	2.2	1.2
4MWA-05T	0.55	0.75	2.3	7	57	0.75	3000	3.4	1.9
4MWA-07T	0.75	1	2.8	9	64	0.75	3000	4.5	2.5
4MWA-11T	1.1	1.5	3.8	15	67	0.76	3000	6.7	3.7
4MWA-15T	1.5	2	4.6	19	69	0.79	3000	9	5
4MWA-22T	2.2	3	7	32	70	0.73	6500	14.1	7.5
4MWA-30T	3	4	9	42	72	0.72	6500	19	10
4MWA-37T	3.7	5	10	44	71	0.76	6500	22	12.4
4MWA-40T	4	5.5	10.3	47	69	0.76	6500	23	12.4
4MWA-55T	5.5	7.5	14	71	70	0.74	6500	33.7	18.7
4MWA-75T	7.5	10	18.5	93	73	0.74	6500	45.2	25.1

### DIMENSIONS AND WEIGHT

Model	Height in (mm)	Nett Weight in Kg
4MWA-03T	410	11.7
4MWA-05T	455	13.3
4MWA-07T	475	15.2
4MWA-11T	525	16.6
4MWA-15T	545	17.1
4MWA-22T	725	27.6
4MWA-30T	750	29.5
4MWA-37T	840	32.9
4MWA-40T	865	32.9
4MWA-55T	900	38.3
4MWA-75T	1085	44.8

ALL DIMENSIONS ARE IN mm  
 SPLINED SHAFT : 14 TEETH - MODULE 1.5875  
 PRESSURE ANGLE 30°, A.N.S.I. B-92-1-1970 COUPLING CLASS 5

\*Other Voltages 400V & 415V also offered on request

# WATER FILLED SUBMERSIBLE MOTORS - REWINDABLE

Nominal Diameter : 6"



## SPECIFICATIONS

Power Range	4 kW to 45 kW - 3 Ph
Version	3 Ph - 380 V, 415 V & 525 V, 50 Hz, A.C Supply
Speed	2900 rpm
Insulation Class	Y
Duty Type	S1 (Continuous)
Degree of Protection	IP 58 / IP 68
Direction of Rotation	Electrically Reversible - 3Ph
Down Thrust Load	4 kW to 22 kW - 15500 N 26 kW to 45 kW - 27500 N
Minimum Cooling Flow along the Motor	0.15 m/sec
Maximum Liquid Temperature	33°C
Starts per Hour	20 Times
Mounting Standard	NEMA Standard
Method of Starting	4 kW to 45 kW - Direct On Line (DOL) 5.5 kW to 45 kW - Star Delta (SD)
Cable Lead Out	Permanently connected and sealed 3/4 core TPE/EPDM Rubber flat cable
Thermal Protection	Optional PT Sensor



# WATER FILLED SUBMERSIBLE MOTORS - REWINDABLE

Nominal Diameter : 6"

## TECHNICAL DATA

### 6" 3 Ph 380V, 415 V

Models		Motor Power		Full Load Max (A)	Starting Current (A)	Eff. %	Power Factor	Max. Down Thrust Load (N)	Starting Torque (Nm)	Torque (Nm)
D.O.L	S.D	kW	HP							
6MWA-40T	-	4	5.5	11	41	76	0.72	15500N	20	14
6MWA-45T	-	4.5	6	12.5	46	76	0.77	15500N	21	15
6MWA-55T	6MWA-55D	5.5	7.5	13.7	50	78	0.78	15500N	24	18
6MWA-75T	6MWA-75D	7.5	10	19	67	82	0.76	15500N	27	25
6MWA-93T	6MWA-93D	9.3	12.5	22	81	82	0.8	15500N	35	31
6MWA-110T	6MWA-110D	11	15	26	99	82	0.81	15500N	43	37
6MWA-130T	6MWA-130D	13	17.5	30	115	83	0.81	15500N	51	43
6MWA-150T	6MWA-150D	15	20	34	145	83	0.82	15500N	62	49
6MWA-185T	6MWA-185D	18.5	25	43	185	83	0.82	15500N	98	61
6MWA-220T	6MWA-220D	22	30	50	222	83	0.82	15500N	115	73
6MWA-260T	6MWA-260D	26	35	57	267	83	0.83	27500N	130	85
6MWA-300T	6MWA-300D	30	40	68	352	83	0.83	27500N	190	97
6MWA-370T	6MWA-370D	37	50	84	416	82	0.82	27500N	240	122
6MWA-450T	6MWA-450D	45	60	95	461	82	0.82	27500N	390	150

### 6" 3 Ph 525V, D.O.L. & S.D. MOTORS

Model		Motor Power		Full Load Max (A)	Starting Current (A)	Full load		Max. Down Thrust Load (N)	Starting Torque (Nm)	Torque (Nm)
D.O.L	S.D	kW	HP			Eff. %	Power Factor			
6MWA-55TN	6MWA-55DN	5.5	7.5	11	45	79.3	0.72	15500	24	18.4
6MWA-75TN	6MWA-75DN	7.5	10	15	60	75	0.81	15500	28	24.5
6MWA-93TN	6MWA-93DN	9.3	12.5	19.5	85	78.3	0.8	15500	35	30.6
6MWA-110TN	6MWA-110DN	11	15	20	95	82.5	0.8	15500	43.2	36.7
6MWA-130TN	6MWA-130DN	13	17.5	22.5	112	83	0.82	15500	51	43
6MWA-150TN	6MWA-150DN	15	20	27	135	82.5	0.82	15500	61.8	49
6MWA-185TN	6MWA-185DN	18.5	25	30.5	152	86	0.82	15500	98.1	61.3
6MWA-220TN	6MWA-220DN	22	30	38	180	83	0.8	15500	118	73.5
6MWA-260TN	6MWA-260DN	26	35	44	200	83.5	0.83	27500	138.3	85.8
6MWA-300TN	6MWA-300DN	30	40	51	235	84	0.83	27500	196.1	98.1
6MWA-370TN	6MWA-370DN	37	50	63	285	85	0.85	27500	245	122.6
6MWA-450TN	6MWA-450DN	45	60	75	340	85.5	0.85	27500	396	150

\*Other Voltages 400V & 415V also offered on request

# TECHNICAL DATA

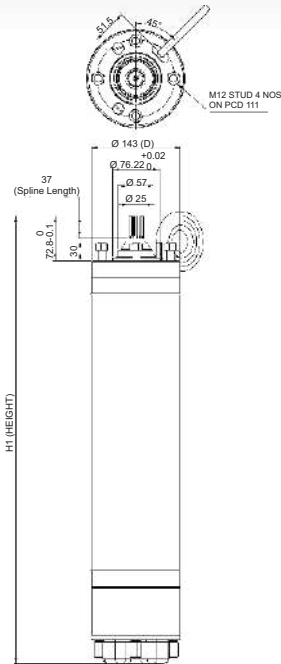

All Dimensions are in mm  
 Splined Shaft - 15 teeth -  
 Module 1.5875  
 Pressure Angle 30°  
 A.N.S.I.B-92-1-1970  
 Tolerance Class 5

Models		Motor Power		Reduced Diameter - Flange Type		
				Dimension (mm)		Nett Weight (kg) (Approx)
D.O.L	S.D	kW	HP	D	H1	
6MWA-22T	6MWA-22D	2.2	3	138	690	44
6MWA-30T	6MWA-30D	3	4	138	700	47
6MWA-37T	6MWA-37D	3.7	5	138	730	48
6MWA-45T	6MWA-45D	4.5	6	138	770	52
6MWA-55T	6MWA-55D	5.5	7.5	138	820	56
6MWA-75T	6MWA-75D	7.5	10	138	865	60
6MWA-93T	6MWA-93D	9.3	12.5	138	895	63
6MWA-110T	6MWA-110D	11	15	138	930	67
6MWA-130T	6MWA-130D	13	17.5	138	970	70
6MWA-150T	6MWA-150D	15	20	138	1020	77
6MWA-185T	6MWA-185D	18.5	25	138	1070	84

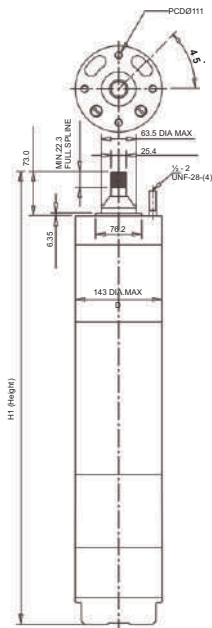

All dimensions are in mm  
 Splined shaft 15 Teeth - module 1.5875  
 Pressure angle 30° A.N.S.I.B - 92 - 1 - 1970  
 Coupling Class 5

Models		Motor Power		Tie Bolt - B Type		
				Dimension (mm)		Nett Weight (kg) (Approx)
D.O.L	S.D	kW	HP	D	H1	
6MWA-40T	6MWA-40D	4	5.5	144	727	48.9
6MWA-45T	6MWA-45D	4.5	6	144	742	49.8
6MWA-55T	6MWA-55D	5.5	7.5	144	797	55.9
6MWA-75T	6MWA-75D	7.5	10	144	837	60.5
6MWA-93T	6MWA-93D	9.3	12.5	144	867	63.8
6MWA-110T	6MWA-110D	11	15	144	897	67.2
6MWA-130T	6MWA-130D	13	17.5	144	937	70.3
6MWA-150T	6MWA-150D	15	20	144	982	77.5
6MWA-185T	6MWA-185D	18.5	25	144	1047	84.6
6MWA-220T	6MWA-220D	22	30	144	1152	93.5
6MWA-260T	6MWA-260D	26	35	144	1192	97.4
6MWA-300T	6MWA-300D	30	40	144	1227	103.3
6MWA-370T	6MWA-370D	37	50	144	1302	110.6
6MWA-450T	6MWA-450D	45	60	144	1377	121.5

\*Other Voltages 400V & 415V also offered on request

## TECHNICAL DATA

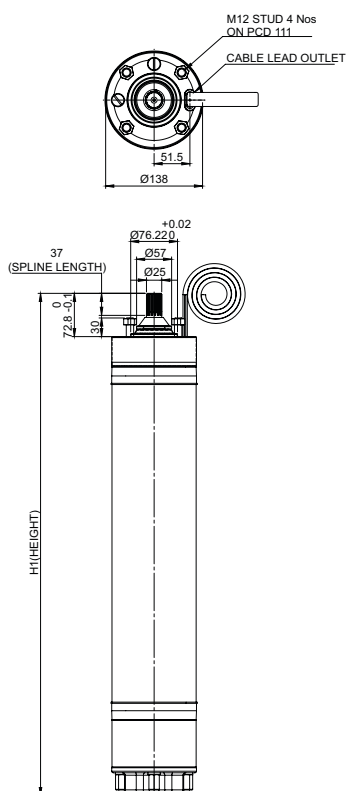
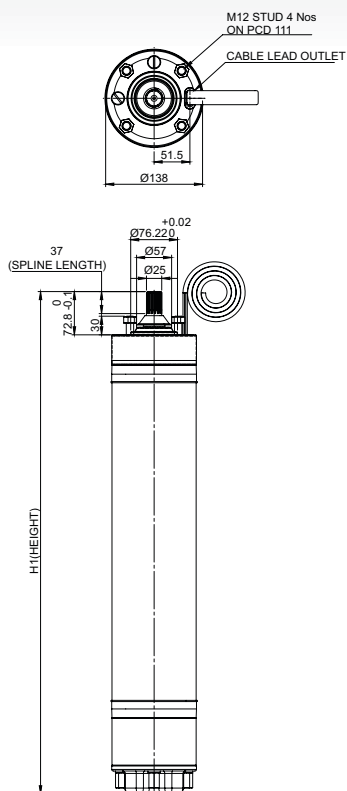

Models		Motor Power		Reduced Diameter Tie Bolt B Type		
D.O.L	S.D	kW	HP	Dimension (mm)		Nett Weight (kg) (Approx)
				D	H1	
6MWA-40T	-	4	5.5	143	734	42
6MWA-45T	-	4.5	6	143	754	44
6MWA-55T	6MWA-55D	5.5	7.5	143	804	50
6MWA-75T	6MWA-75D	7.5	10	143	854	55
6MWA-93T	6MWA-93D	9.3	12.5	143	884	58
6MWA-110T	6MWA-110D	11	15	143	924	63
6MWA-130T	6MWA-130D	13	17.5	143	964	67
6MWA-150T	6MWA-150D	15	20	143	1004	71
6MWA-185T	6MWA-185D	18.5	25	143	1084	80
6MWA-220T	6MWA-220D	22	30	143	1154	86
6MWA-260T	6MWA-260D	26	35	143	1174	89
6MWA-300T	6MWA-300D	30	40	143	1229	94
6MWA-370T	6MWA-370D	37	50	143	1304	98
6MWA-450T	6MWA-450D	45	60	143	1379	105

Models		Motor Power		Flange Type		
D.O.L	S.D	kW	HP	Dimension (mm)		Nett Weight (kg) (Approx)
				D	H1	
6MWA-55T	6MWA-55D	5.5	7.5	144	793	57
6MWA-75T	6MWA-75D	7.5	10	144	843	62
6MWA-93T	6MWA-93D	9.3	12.5	144	873	65
6MWA-110T	6MWA-110D	11	15	144	913	67
6MWA-130T	6MWA-130D	13	17.5	144	953	72
6MWA-150T	6MWA-150D	15	20	144	993	77
6MWA-185T	6MWA-185D	18.5	25	144	1073	85

\*Other Voltages 400V & 415V also offered on request

# WATER FILLED SUBMERSIBLE MOTORS - REWINDABLE

Nominal Diameter : 8"



## SPECIFICATIONS

Power Range	37 kW to 93 kW - 3 Ph
Version	3 Ph - 380 V, 415 V & 525 V, 50 Hz, A.C Supply
Speed	2900 rpm
Insulation Class	Y
Duty Type	S1 (Continuous)
Degree of Protection	IP 68
Direction of Rotation	Electrically Reversible - 3 Ph
Down Thrust Load	45500 N
Minimum Cooling Flow along the Motor	0.16 m/sec
Maximum Liquid Temperature	33°C
Starts per Hour	15 Times
Mounting Standard	NEMA Standard
Method of Starting	Direct On Line (DOL) Star Delta (SD)
Cable Lead Out	Permanently connected and sealed 3/4 core TPE/EPDM Rubber insulated flat cable
Thermal Protection	Optional PT Sensor

# WATER FILLED SUBMERSIBLE MOTORS - REWINDABLE

Nominal Diameter : 8"

## TECHNICAL DATA

### 8" 3 Ph 380V, 415 V

Model		Motor Power		Full Load Max (A)	Starting Current (A)	Full load		Max.Down Thrust Load (N)	Starting Torque (Nm)	Torque (Nm)
DOL	SD	kW	HP			Eff. %	Power Factor			
8MWB-370T	8MWB-370D	37	50	69	380	83.6	0.86	45500	160	122
8MWB-450T	8MWB-450D	45	60	94.5	480	84	0.87	45500	225	148
8MWB-550T	8MWB-550D	55	75	116	620	84.5	0.87	45500	310	182
8MWB-630T	8MWB-630D	63	85	130	710	85	0.87	45500	350	208
8MWB-750T	8MWB-750D	75	100	156	855	85	0.88	45500	420	248
8MWB-930T	8MWB-930D	93	125	186	1050	87	0.87	45500	570	308

### 8" 3 Ph 525V, D.O.L. & S.D. MOTORS

Model		Motor Power		Full Load Max (A)	Starting Current (A)	Full load		Max.Down Thrust Load (N)	Starting Torque (Nm)	Torque (Nm)
DOL	SD	kW	HP			Eff. %	Power Factor			
8MWB-450TN	8MWB-450DN	45	60	80	320	85	0.82	45500	320	154
8MWB-550TN	8MWB-550DN	55	75	92	365	85	0.84	45500	450	185
8MWB-630TN	8MWB-630DN	63	85	103	410	86	0.88	45500	500	211
8MWB-750TN	8MWB-750DN	75	100	118	470	87	0.9	45500	620	251
8MWB-930TN	8MWB-930DN	93	125	145	580	87	0.88	45500	685	311

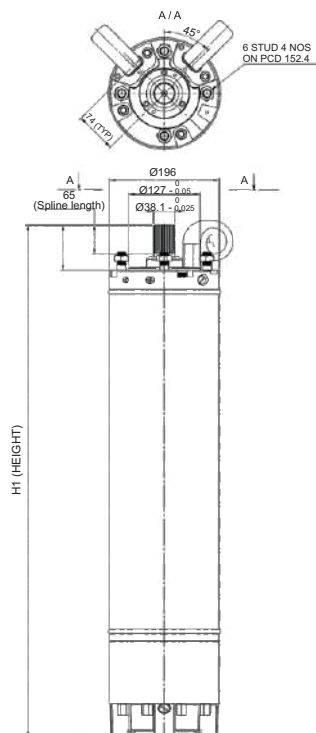

### 8" 3 Ph 380V, 415 V

Model		Motor Power		Dimensions (mm)		Nett Weight (kg) (Approx)
DOL	SD	kW	HP	D	H1	
8MWB-370T	8MWB-370D	37	50	196	1181	153
8MWB-450T	8MWB-450D	45	60	196	1231	164
8MWB-550T	8MWB-550D	55	75	196	1281	180
8MWB-630T	8MWB-630D	63	85	196	1351	193
8MWB-750T	8MWB-750D	75	100	196	1466	215
8MWB-930T	8MWB-930D	93	125	196	1556	235

\*Other Voltages 400V & 415V also offered on request

All Dimensions are in mm  
 Splined Shaft : 23 teeth -  
 Module 1.5875 Pressure Angle 30°  
 A.N.S.I.B92-1 Tolerance Class 5

# WATER FILLED SUBMERSIBLE MOTORS - REWINDABLE

Nominal Diameter : 10"



Type - A/N

Type - B

## SPECIFICATIONS

Power Range	81 kW to 220 kW
Version	3 Ph - 380 V, 415 V, 50 Hz, A.C Supply
Speed	2900 rpm
Insulation Class	Y
Duty Type	S1 (Continuous)
Degree of Protection	IP 68
Direction of Rotation	Electrically Reversible - 3 Ph
Down Thrust Load	60000 N
Minimum Cooling Flow along the Motor	0.16 m/sec
Maximum Liquid Temperature	33°C
Starts per Hour	10 Times
Mounting Standard	NEMA Standard
Method of Starting	Direct On Line (DOL) Star Delta (SD)
Cable Lead Out	Permanently connected and sealed 3/4 core TPE/EPDM Rubber insulated flat cable
Thermal Protection	Optional PT Sensor

# WATER FILLED SUBMERSIBLE MOTORS - REWINDABLE

Nominal Diameter : 10"

## TECHNICAL DATA

### 10" 3 Ph 380V - 415 V DOL & SD MOTORS

Model		Motor Power		Full Load Max (A)	Starting Current (A)	Eff. %	Power Factor	Max. Down Thrust Load (N)
DOL	SD	kW	HP					
10MWA-750T	10MWA-750D	75	100	150	1500	86	0.87	60000
10MWA-810T	10MWA-810D	81	110	166	1600	86	0.87	60000
10MWA-930T	10MWA-930D	93	125	181	1810	87	0.89	60000
10MWA-A10T	10MWA-A10D	110	150	220	2200	87	0.89	60000
10MWA-A30T	10MWA-A30D	130	175	255	2550	87	0.89	60000
10MWA-A50T	10MWA-A50D	150	200	290	2900	88	0.89	60000
10MWA-A65T	10MWA-A65D	165	225	325	3250	88	0.89	60000
10MWA-A85T	10MWA-A85D	185	250	355	3550	89	0.90	60000
10MWA-B22T	-	220	300	425	4250	88	0.86	60000

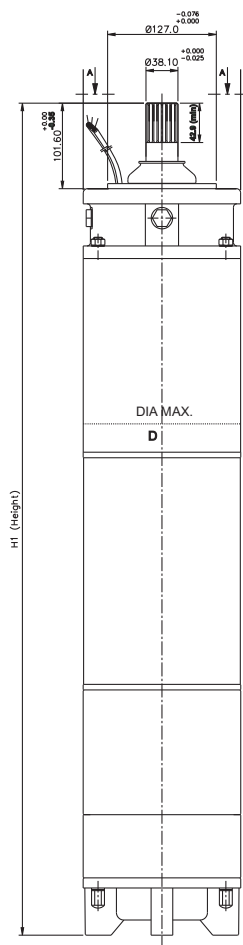

ALL DIMENSIONS ARE IN mm.

### 10" 3 Ph 380V - 415 V DOL & SD MOTORS

Model		Motor Power		Dimension (mm)		Nett Weight (kg) (Approx)
DOL	SD	kW	HP	D	H1	
10MWA-750T	10MWA-750D	75	100	232	1226	240
10MWA-810T	10MWA-810D	81	110	232	1481	290
10MWA-930T	10MWA-930D	93	125	232	1551	298
10MWA-A10T	10MWA-A10D	110	150	232	1631	319
10MWA-A30T	10MWA-A30D	130	175	232	1741	340
10MWA-A50T	10MWA-A50D	150	200	232	1811	360
10MWA-A65T	10MWA-A65D	165	225	232	1891	387
10MWA-A85T	10MWA-A85D	185	250	232	1981	414
10MWA-B22T	-	220	300	232	2183	500

\*Other Voltages 400V & 415V also offered on request

# OIL FILLED SUBMERSIBLE MOTORS

## OIL FILLED MOTORS

Oil Filled Motors are prefilled with food grade edible oil and is rewindable submersible motors Frictionless ball and angular contact bearings are used to carry the radial and axial thrust loads. These motors are sealed with oil seal, 'O' rings & mechanical seal to withstand in various operating conditions and it prevents entry of foreign particles. The pressure equalizing diaphragm is provided to balance the pressure & volume variation due to thermal expansion inside the motors. All single phase motors are fitted with thermal overload protector. It is mandatory to use Gransa make control box for trouble free operation. All mounting dimensions of these motors are in accordance with NEMA standard.



### Features :

- | High operating efficiency and lesser power consumption.
- | Extremely hardwearing ball & angular contact bearings
- | Corrosive resistance stainless steel body
- | Filled with non-toxic oil
- | Can be easily dismantled and repaired.

### Applications :

- | Residential
- | Irrigation
- | Fountains
- | Gardens
- | Sprinkler Systems
- | Pressure Boosting units
- | Ponds





# OIL FILLED SUBMERSIBLE MOTORS

Nominal Diameter : 4"

## CROSS SECTIONAL DRAWING

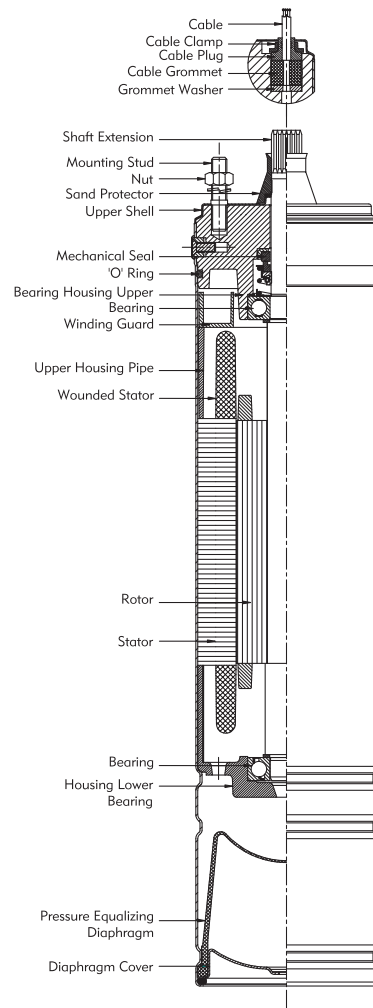

## MATERIALS OF CONSTRUCTION

Part Name	Type - A
Outer Shell	SS - 304
Motor Base	SS - 304
Shaft Extension	SS - 420
'O' Ring	High Nitrile Rubber
Mechanical Seal	Carbon / Ceramic
Diaphragm	High Nitrile Rubber
Cable	TPE / EPDM

# OIL FILLED SUBMERSIBLE MOTORS

Nominal Diameter : 4"



## SPECIFICATIONS

Power Range	0.37 kW to 2.2 kW - 1 Ph
	0.37 kW to 7.5 kW - 3 Ph
Version	1 Ph - 230 V, 50 Hz, A.C Supply
	3 Ph - 380 - 415 V, 50 Hz, A.C Supply
Speed	2900 rpm
Insulation Class	F
Duty Type	S1 (Continuous)
Degree of Protection	IP 68
Down Thrst Load	0.37 kW to 0.75 kW - 1500 N
	1.1 kW to 4.0 kW - 2500 N
	5.5 kW to 7.5 kW - 4500 N
Minimum Cooling Flow along the Motor	0.15 m/sec
Maximum Liquid Temperature	33°C
Maximum Immersion Depth	150 m
Starts per Hour	30 Times
Mounting Standard	NEMA Standard
Method of Starting	1 Ph - Permanent Split Capacitor (PSC)
	3 Ph - Direct On Line (DOL)

# OIL FILLED SUBMERSIBLE MOTORS

Nominal Diameter : 4"

## TECHNICAL DATA

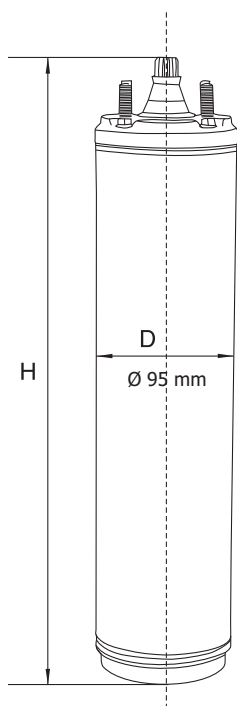

### 1 Ph - 230V

Model	kW	HP	F.L. Current (A)	Starting Current (A)	Efficiency (%)	Power Factor	Capacitor (MFD)	Thrust Load (N)	Height in (mm)	Nett Weight in Kg
4MLA-03N	0.37	0.5	3.6	10.4	53	0.88	15	1500	357	8
4MLA-05N	0.55	0.75	4.8	13.6	58	0.89	20	1500	377	8
4MLA-07N	0.75	1	6.3	17.6	60	0.90	30	1500	402	9
4MLA-11N	1.1	1.5	8.6	21.1	64	0.90	40	2500	432	11
4MLA-15N	1.5	2	10	26.4	70	0.94	50	2500	475	12
4MLA-22N	2.2	3	14	39.9	74	0.96	60	2500	520	14

### 3 Ph - 380V - 415 V

Model	kW	HP	F.L. Current (A)	Starting Current (A)	Efficiency (%)	Power Factor	Thrust Load (N)	Height in (mm)	Nett Weight in Kg
4MLA-03T	0.37	0.5	1.07	5.2	63	0.80	1500	392	8
4MLA-05T	0.5	0.75	1.9	9.3	63	0.80	1500	407	8
4MLA-07T	0.75	1	2.4	11.1	64	0.81	1500	427	9
4MLA-11T	1.1	1.5	3.15	13	68	0.82	2500	447	10
4MLA-15T	1.5	2	4.2	19.5	72	0.82	2500	482	11
4MLA-22T	2.2	3	6	28	72	0.83	2500	542	14
4MLA-30T	3	4	7.8	40.2	75	0.83	2500	602	19
4MLA-37T	3.7	5	9.6	48	75	0.83	2500	602	19
4MLA-40T	4	5.5	10	51	77	0.83	2500	642	21
4MLA-55T	5.5	7.5	13.6	71.1	78	0.85	4500	762	25
4MLA-75T	7.5	10	17.6	87.8	79	0.85	4500	882	31

# OIL FILLED SUBMERSIBLE MOTORS

Nominal Diameter : 6"



## SPECIFICATIONS

Power Range	5 kW to 45 kW - 3 Ph
Version	1 Ph - 230 V, 50 Hz, A.C Supply
	3 Ph - 380 - 415 V, 50 Hz, A.C Supply
Speed	2880 rpm
Insulation Class	F
Duty Type	S1 (Continuous)
Degree of Protection	IP 68
Down Thrst Load	5 kW to 15 kW - 15000 N
	17.5 kW to 45 kW - 30000 N
Minimum Cooling Flow along the Motor	0.16 m/sec
Maximum Liquid Temperature	33°C
Starts per Hour	20 Times
Mounting Standard	NEMA Standard
Method of Starting	3 Ph - Direct On Line (DOL)

# OIL FILLED SUBMERSIBLE MOTORS

Nominal Diameter : 6"

## TECHNICAL DATA

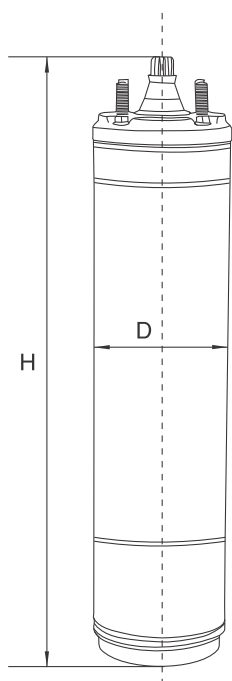

### THREE PHASE, 380V

Model	kW	HP	F.L. Current (A)	Starting Current (A)	Efficiency (%)	Power Factor	Speed rpm	Max. Down Thrust Load (N)
6MLB-55T	5.5	7.5	12.9	58	76	0.83	2850	15500
6MLB-75T	7.5	10	16.5	76	76.5	0.85	2850	15500
6MLB-93T	9.3	12.5	19.5	105	77	0.87	2850	15500
6MLB-110T	11	15	23	138	78	0.87	2860	15500
6MLB-130T	13	17.5	26.3	145	79.5	0.88	2860	30000
6MLB-150T	15	20	29.5	200	81	0.88	2860	30000
6MLB-185T	18.5	25	36.3	230	82	0.89	2860	30000
6MLB-220T	22	30	43.1	275	82.5	0.89	2860	30000
6MLB-260T	26	35	50.2	326	82.5	0.90	2860	30000
6MLB-330T	30	40	57.4	366	83	0.90	2860	30000
6MLB-370T	37	50	70.7	440	83.5	0.91	2860	30000
6MLB-450T	45	60	86	522	84	0.91	2860	30000

### DIMENSIONS AND WEIGHT

Model	kW	HP	Dia (mm) D	Height (mm) H	Weight (kg)	Cable Leadouts	
						Cable Size (Sq mm)	Cable Length (m)
6MLB-55T	5.5	7.5	192	580	31	6	2
6MLB-75T	7.5	10	192	620	34.4	6	2
6MLB-93T	9.3	12.5	192	655	38	6	2
6MLB-110T	11	15	192	685	41.4	6	2.1
6MLB-130T	13	17.5	192	715	44	6	2.2
6MLB-150T	15	20	192	755	58.3	6	2.3
6MLB-185T	18.5	25	192	820	61.4	6	2.5
6MLB-220T	22	30	192	880	69	6	2.8
6MLB-260T	26	35	192	930	77	6	4.2
6MLB-330T	30	40	192	980	84	6	4.2
6MLB-370T	37	50	192	1118	92	10	5
6MLB-450T	45	60	192	1178	100	10	5

# RESIN FILLED SUBMERSIBLE MOTORS

## RESIN FILLED MOTORS

These motors are hermetically sealed, encapsulated and water lubricated type with removable cable lead out. The stator windings are of enameled copper wire and the wound stator is mounted in a stainless steel shell and is completely protected by a stainless steel cylinder and stator room is pre-filled with resin. Except stator, other portions of the motor is pre-filled with deionized water which serves as coolant & lubricant for rotor, bushes and thrust bearings. Dynamically balanced rotors of these motors maintain uniform clearance, thereby giving better efficiency and increase the life cycle of the water lubricated bush bearings.

The motor needs constant flow of water passed over its body to keep it at correct operating temperature. Ideally the motors should be set just above the final yield point of bore well and when the level is not ascertained, fit a "flow inducer pipe" over the pumpset to ensure adequate cooling. It is mandatory to use GRANSA Control boxes for all motors (except 2 wire motors) with adequate protection & control systems. Mounting dimensions of these motors are in accordance with NEMA standard.

### Features :

- | Can be easily dismantled & Repaired
- | Higher power factor resulting in lesser power consumption
- | High operating efficiency
- | Extremely hardwearing water lubricated bearings
- | Specially designed thrust bearing to withstand high axial thrust loads
- | Larger shaft diameter for better power transmission
- | Corrosive resistant stainless steel body
- | Stator filled with resin for better heat dissipation

### Applications :

These prime mover submersible motors are suitable to couple with deepwell submersible pumps used for

- | Residential
- | Irrigation
- | Fountains
- | Industrial water supply
- | Pressure boosting units
- | Gardens
- | Sprinkler systems and mining
- | Mining
- | Oil & Gas
- | De-watering



## RESIN FILLED SUBMERSIBLE MOTORS

Nominal Diameter : 4"



### SPECIFICATIONS

Power Range	0.37 kW to 1.1 kW - 1 Ph 2 Wire
	0.37 kW to 2.2 kW - 1 Ph 3 Wire
	Incorporated with Thermal protector upto 0.75kW
	0.37 kW to 7.5 kW - 3 Ph 3 Wire
Version	1 Ph - 230 V, 50 Hz, A.C Supply
	3 Ph - 380 - 415 V, 50 Hz, A.C Supply
Speed	2900 rpm
Insulation Class	B
Duty Type	S1 (Continuous)
Degree of Protection	IP 68
Down Thrst Load	0.37 kW to 0.55 kW - 1500N
	0.75 kW to 1.5 kW - 3000N
	2.2 kW to 7.5 kW - 6500N
Minimum Cooling Flow along the Motor	0.15 m/sec
Maximum Liquid Temperature	33°C
Starts per Hour	20 Times
Mounting Standard	NEMA Standard
Method of Starting	1 Ph 3 Wire - Capacitor Start Capacitor Run ( CSCR)
	1 Ph 2 Wire - Permanent Split Capacitor (PSC)
	3 Ph - Direct On Line ( DOL)

# RESIN FILLED SUBMERSIBLE MOTORS

Nominal Diameter : 4"

## TECHNICAL DATA

### 3Ph 220 - 380V, D.O.L 3 WIRE MOTORS

Model	Power		Full Load Current (A)	Starting Current (A)	Full Load		Max. Down Thrust Load (N)	Starting Torque (Nm)	Torque (Nm)
	kW	HP			Eff. (%)	P.F. (%)			
4MRA-03T	0.37	0.50	2.0	7.4	66	78	1,500	2.3	1.3
4MRA-05T	0.55	0.75	2.9	10.0	66	80	1,500	3.1	1.9
4MRA-07T	0.75	1.0	3.6	15.0	67	81	3,000	4.8	2.5
4MRA-11T	1.1	1.5	5.5	25	70	79	3,000	9.4	3.8
4MRA-15T	1.5	2.0	6.9	36	75	83	3,000	13.4	5.0
4MRA-22T	2.2	3.0	10.4	48	71	84	6,500	17.0	7.6
4MRA-30T	3	4.0	13.1	73	72	85	6,500	30.8	10.0
4MRA-37T	3.7	5.0	16.4	80	75	84	6,500	33.6	12.8
4MRA-40T	4	5.5	18.0	102	74	86	6,500	44.4	13.8
4MRA-55T	5.5	7.5	22.8	120	77	83	6,500	48.0	19.0

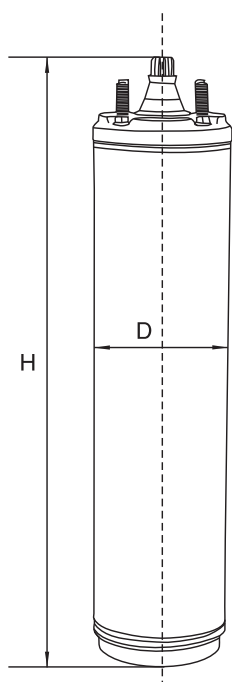

### 3Ph 415V, D.O.L 3 WIRE MOTORS

Model	Power		Full Load Current (A)	Starting Current (A)	Full Load		Max. Down Thrust Load (N)	Starting Torque (Nm)	Torque (Nm)
	kW	HP			Eff. (%)	P.F. (%)			
4MRA-03T	0.37	0.5	1.2	4.9	66	78	1500	3.3	1.26
4MRA-05T	0.55	0.75	1.7	7.8	66	80	1500	5.7	1.89
4MRA-07T	0.75	1.0	2.1	10.6	67	81	3000	8.24	2.52
4MRA-11T	1.1	1.5	3.2	14	70	79	3000	13.6	3.82
4MRA-15T	1.5	2.0	4.0	21	75	83	3000	15.6	5.06
4MRA-22T	2.2	3.0	6.0	28	76	83	6500	23	7.54
4MRA-30T	3.0	4.0	7.6	42	76	85	6500	27	10.3
4MRA-37T	3.7	5.0	9.5	46	75	84	6500	34	12.8
4MRA-40T	4.0	5.5	10.5	55	76	84	6500	41	14.5
4MRA-55T	5.5	7.5	13.0	70	75	86	6500	47	19.1
4MRA-75T	7.5	10.0	18.7	100	76	82	6500	60	25.2

### DIMENSIONS AND WEIGHT

Model		Power		Dimension (mm)			Net Weight (kg) (Approx.)		Cable Leadouts	
1 Phase	3 Phase	kW	HP	D	H 1Phase	H 3Phase	1Phase	3Phase	Cable Size (Sq mm)	Cable Length (m)
4MRA-03S	4MRA-03T	0.37	0.5	95	241	224	8.1	7.2	1.5	1.5
4MRA-05S	4MRA-05T	0.55	0.75	95	269	241	9.5	8.1	1.5	1.5
4MRA-07S	4MRA-07T	0.75	1.0	95	298	269	10.4	9.0	1.5	1.5
4MRA-11S	4MRA-11T	1.1	1.5	95	345	298	13.2	10.4	1.5	1.5
4MRA-15S	4MRA-15T	1.5	2.0	95	384	345	14.6	13.2	1.5	1.5
4MRA-22S	4MRA-22T	2.2	3.0	95	531	454	23.0	18.2	2.0	2.0
-	4MRA-30T	3.0	4.0	95	-	496	-	20.0	2.0	2.0
-	4MRA-37T	3.7	5.0	95	-	531	-	23.0	2.0	2.0
-	4MRA-40T	4.0	5.5	95	-	556	-	24.0	2.0	2.0
-	4MRA-55T	5.5	7.5	95	-	686	-	30.0	2.0	3.0
-	4MRA-75T	7.5	10.0	95	-	756	-	34.0	2.0	3.0



## RESIN FILLED SUBMERSIBLE MOTORS

Nominal Diameter : 6"



### SPECIFICATIONS

Power Range	4 kW to 45 kW - 3 Ph
Version	3 Ph - 380 - 415 V, 50 Hz, A.C Supply
Speed	2900 rpm
Insulation Class	F
Degree of Protection	IP 68
Duty Type	S1 (Continuous)
Down Thrust Load	27500
Minimum Cooling Flow along the Motor	0.16 m/sec
Maximum Liquid Temperature	33°C
Starts per Hour	20 Times
Mounting Standard	NEMA Standard
Method of Starting	3 Ph - Direct On Line (DOL)

# RESIN FILLED SUBMERSIBLE MOTORS

Nominal Diameter : 6"

## TECHNICAL DATA

### 3 Ph - 380 - 415V, D.O.L. MOTORS

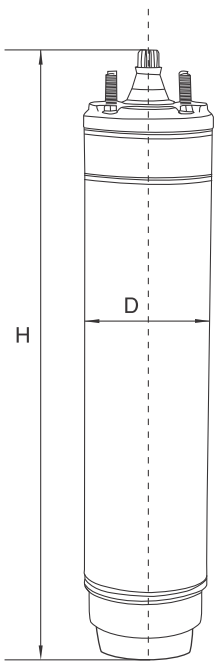

Model	Power		Full Load Current (A)	Locked Rotor Amps	Full Load		Max. Down Thrust Load (N)	Torque (Nm)
	kW	HP			Eff. (%)	P.F.		
6MRA-40T	4	5.5	9.8	41	78	0.82	15500	12.3
6MRA-55T	5.5	7.5	13	62	78	0.82	15500	18.6
6MRA-75T	7.5	10	17.8	81	78	0.86	15500	25
6MRA-93T	9.3	12.5	21.7	105	80	0.8	15500	31.1
6MRA-110T	11	15	23.8	118	80	0.85	15500	37.3
6MRA-150T	15	20	31.3	159	81	0.85	15500	49.9
6MRA-185T	18.5	25	38.3	220	82	0.85	15500	62.4
6MRA-220T	22	30	45.6	256	83	0.86	15500	74.7
6MRA-300T	30	40	63.4	381	83	0.84	27500	99.4
6MRA-370T	37	50	72.8	405	84.5	0.87	27500	123.6
6MRA-450T	45	60	93.4	504	86	0.84	27500	148.4

### DIMENSIONS AND WEIGHT

Model	Power		Dimension (mm)		Net Weight (kg) (Approx.)	Cable Size (Sq mm)	Cable Length (m)
	kW	HP	D	H1			
6MRA-40T	4	5	139	546	34.5	4	3
6MRA-55T	5.5	7.5	139	579	37.8	4	3
6MRA-75T	7.5	10	139	611	41	4	3
6MRA-93T	9.3	12.5	139	644	44.3	4	3
6MRA-110T	11	15	139	676	46.5	4	3
6MRA-150T	15	20	139	741	53	4	3
6MRA-185T	18.5	25	139	806	59.5	4	3
6MRA-220T	22	30	139	871	66	4	3
6MRA-300T	30	40	139	1001	79	4	3
6MRA-370T	37	50	139	1388	117	4	3
6MRA-450T	45	60	139	1540	132	4	3

# CABLE SELECTION

## FOR SINGLE PHASE 3 WIRE (D.O.L) MOTOR MAXIMUM LENGTH OF COPPER CABLE

Motor Rating			Cable Size in Square Millimetres						MAXIMUM LENGTH IN METRES
VOLTS	kW	HP	1.5	2.5	4	6	10	16	
230 VOLT 50Hz	0.37	0.5	120	200	320	480	810		
	0.55	0.75	80	130	220	320	550		
	0.75	1	60	100	170	250	430		
	1.1	1.5	40	70	120	180	300		
	1.5	2	30	60	90	130	230	360	
	2.2	3		40	60	90	150	230	

## FOR THREE PHASE 6WIRE (S/D) MOTOR MAXIMUM LENGTH OF COPPER CABLE

Voltage drop - 3%

Motor Rating			Cable Size in Square Millimetres																		MAXIMUM LENGTH IN METRES		
VOLTS	kW	HP	1.5	2.5	4	6	10	16	25	35	50	70	95	120	150	185	240	300	400	500		630	
380-415 VOLT 50Hz	5.5	7.5	91	143	234	351	572	896	1377	1884													
	7.5	10	65	104	169	260	403	650	974	1338													
	9.3	12.5		91	143	221	364	572	870	1182	1624												
	11	15		78	130	182	299	481	714	974	1377	1832											
	13	17.5			104	143	260	403	611	844	1156	1533											
	15	20			91	130	221	351	533	740	1026	1364	1741										
	18.5	25				104	182	273	429	585	799	1065	1364	1624									
	22	30					156	234	364	494	688	922	1169	1403	1650								
	26	35					130	195	299	403	572	792	1000	1221	1429	1650							
	30	40					117	169	273	364	520	675	870	1013	1208	1390	1624						
	37	50						143	221	299	416	546	701	831	974	1117	1312	1494					
	45	60							182	247	338	468	598	727	870	1013	1208	1377					
	55	75								208	286	377	494	611	714	831	987	1137					
	63	85								188	260	299	442	546	637	740	870	1000					
	75	100									208	286	377	455	533	611	727	831	974				
	93	125										234	299	364	429	494	585	662	779				
	110	150												260	312	377	429	520	598	701	786		
	130	175													221	266	325	377	442	520	598	688	760
	150	200														234	279	325	390	455	539	604	669
	166	225															234	286	338	390	455	520	578
185	250																260	312	364	429	481	539	
220	300																	247	286	331	372	410	
260	350																		247	286	325	357	
300	400																			214	247	273	312

These are maximum length of cable in METRES from POWER SOURCE to MOTOR. Exceeding these length will void warranty.

# CABLE SELECTION

## FOR THREE PHASE 3 WIRE (D.O.L.) MOTOR MAXIMUM LENGTH OF COPPER CABLE

Voltage drop - 3%

Motor Rating			Cable Size in Square Millimetres																		MAXIMUM LENGTH IN METRES		
VOLTS	kW	HP	1.5	2.5	4	6	10	16	25	35	50	70	95	120	150	185	240	300	400	500		630	
380-415 VOLT 50Hz	0.37	0.5	473	788	1260																		
	0.55	0.75	398	660	1050																		
	0.75	1	311	518	825																		
	1.1	1.5	203	338	533	795																	
	1.5	2	161	270	428	638																	
	2.2	3	113	188	300	450	731																
	3	4	86	143	233	345	566	885															
	3.7	5	71	120	188	285	465	735															
	4	5.5	67	113	176	263	435	683	1043														
	4.5	6	64	105	169	255	420	653	998	1358													
	5.5	7.5	53	83	135	203	330	518	795	1088													
	7.5	10	38	60	98	150	233	375	563	773													
	9.3	12.5		53	83	128	210	330	503	683	938												
	11	15		45	75	105	173	278	413	563	795	1058											
	13	17.5			60	83	150	233	353	488	668	885											
	15	20			53	75	128	203	308	428	593	788	1005										
	18.5	25				60	105	158	248	338	461	615	788	938									
	22	30					90	135	210	285	398	533	675	810	953								
	26	35					75	113	173	233	330	458	578	705	825	953							
	30	40					68	98	158	210	300	390	503	585	698	803	938						
	37	50						83	128	173	240	315	405	480	563	645	758	863					
	45	60							105	143	195	270	345	420	503	585	698	795					
	55	75								120	165	218	285	353	413	480	570	656					
	63	85								109	150	173	255	315	368	428	503	578					
	75	100									120	165	218	263	308	353	420	480	563				
	93	125										135	173	210	248	285	338	383	450				
	110	150											150	180	218	248	300	345	405	454			
	130	175												128	154	188	218	255	300	345	398	439	
	150	200													135	161	188	225	263	311	349	386	
	166	225														135	165	195	225	263	300	334	
185	250															150	180	210	248	278	311		
220	300																143	165	191	215	237		
260	350																	143	165	188	206		
300	400																		124	143	158	180	

These are maximum length of cable in METRES from POWER SOURCE to MOTOR. Exceeding these length will void warranty.

# G E N E R A L I N F O R M A T I O N

## CURVE CONDITIONS

The conditions below apply to the curves shown in this catalogues.

1. The Performance curves show pump performance at rated speed, voltage and @ 10ft minimum submergence.  
The nominal speed of motor for 3", 4", 6", 8" & 10" : n = 2800 rpm
2. Pipe friction losses have not been included in the performance curves and performance tables.
3. Q/H : The curves are inclusive of check valve and suction inter-connector losses at the actual speed.
4. The bold curves indicate the recommended performance range.
5. The measurements were made with airless water at 20°C. When pumping liquids with a density higher than that of water, motors with correspondingly higher outputs must be used.
6. Efficiency curve : "η%" shows pump stage efficiency.
7. Curve tolerance according to ISO : 9906, Grade - 3B
8. The given performances are for specific materials of construction of pump.

## IDENTIFICATION

**DEEPWELL SUBMERSIBLE PUMP**

	<b>X G X C - XXX / XX X X</b>
Nominal Pump Diameter	←
Gransa Sub Pump	←
Type Of M.O.C.	←
Casted Version (optional)	←
NOMINAL FLOW (m <sup>3</sup> /h) To include decimal values in the nominal flow from 0.1 to 0.8 alphabets A-H are used.	←
Number of stages	←
NOMINAL MOTOR DIAMETER (Applicable only when the pump is suitable for lesser dia motor)	←
Mining Application (Applicable only for pumps suitable to Mining applications)	←

<b>DEEPWELL SUBMERSIBLE PUMP SET (Pump + Motor)</b>		
<b>PUMP MODEL</b>	<b>+</b>	<b>MOTOR MODEL</b>
<b>X P X - XXX / XX</b>	<b>+</b>	<b>X M X X - XXX X</b>
<b>DEEPWELL SUBMERSIBLE PUMP SET (Pump + Motor)</b>		
<b>PUMP MODEL</b>	<b>+</b>	<b>MOTOR MODEL</b>
<b>6GS - 18 / 03</b>	<b>+</b>	<b>6MWB - 20D</b>

# BOREWELL SUBMERSIBLE PUMPS

Gransa borewell submersible pumps are designed with optimal efficiency to give trouble free running for many years. All major components in the pumps are made of corrosion free Stainless Steel 304/316 grade and shaft is made up of Stainless Steel 304/329/431 grades to ensure durability. These pumps are of multistage centrifugal type fitted with radial and mixed flow impellers & firmly supported with intermediate bearings for long life and built in check valve to avoid water hammer during stop of pump. All mounting dimension of these pumps are in accordance with NEMA standards and it can be coupled with any suitable motors.



## Special Features :

- | Additional intermediate bearings in higher stage pumps
- | SS 329 grade for spline coupling which ensure long life / durability
- | Special pumps for special applications like coal bed methane

## Applications :

- | Residential
- | Community water supply
- | Irrigation
- | Sprinkler Systems
- | Utility water supply in industries
- | Pressure Boosting application
- | Mining
- | De-watering



## GS SERIES

### PUMPED LIQUIDS

Clean, thin, non-aggressive, non explosive, clear, cold, fresh water without abrasives, solid particles or fibre having the following characteristics

a)	<b>Temperature (max)</b>	NBR - 33°C / VITON - 90°C
b)	<b>Permissible amount of sand</b>	50g/m <sup>3</sup> (max)
c)	<b>Chlorine ion density</b>	500 ppm (max)
d)	<b>Allowable solids</b>	3000 ppm (max)
e)	<b>Specific gravity</b>	1.004 (max)
f)	<b>Hardness (Drinking water)</b>	300 (max)
g)	<b>Viscosity</b>	1.75 x 10 <sup>-6</sup> m <sup>2</sup> /sec (max)
h)	<b>Turbidity</b>	50 ppm silica scale (max)
i)	<b>pH</b>	6.5 to 8.5

PUMP OPERATING LIMITATIONS					
Nominal Diameter		4"(100mm)	6"(150mm)	8"(200mm)	10"(250mm)
<b>Power Range</b>		0.37 - 11 kW	2.2 - 63 kW	5.5 - 130 kW	9.3 - 220 kW
<b>Speed</b>		2900 rpm	2900 rpm	2900 rpm	2900 rpm
<b>Discharge Range</b>	<b>m<sup>3</sup>/h</b>	0.4 - 19	7 - 80	20 - 126	18 - 280
	<b>lps</b>	0.12 - 5.28	1.94 - 22.24	5.5 - 35	5 - 77.78
<b>Total head range</b>	<b>m</b>	4.0 - 535	4.5 - 620	8 - 518	6 - 488
	<b>ft</b>	13.0 - 1755	15 - 2132	26 - 1558	19.68 - 1600
<b>Outlet size in inches</b>		1¼, 1½ & 2	2, 2½, 3 & 4	4 & 5	6
<b>Shaft Coupling</b>		Splines	Splines	Splines	Keyway / Splines

#### Maximum temperature of Pumped liquid

Motor	Minimum cooling flow along the motor	Vertical installation	Horizontal installation (minimum 30°angle)
4" & 6"	0.15 m/s	NBR-33°C VITON-90°C	NBR-33°C VITON-90°C
8" & 10"	0.16 m/s		

Maximum operating pressure	
4" Submersible pump	5.4 Mpa (54 bar)
6" Submersible pump	6.2 Mpa (62 bar)
8" Submersible pump	4.8 Mpa (48 bar)
10" Submersible pump	4.9 Mpa (49 bar)

# GS SERIES

## TYPES OF CONSTRUCTION

PART NAME	NOMINAL DIA. 4"		NOMINAL DIA . 6", 8" & 10"	
	TYPE - S	TYPE - N	TYPE - S	TYPE - N
CHECK VALVE HOUSING	SS - 304	SS - 316	SS - 304	SS - 316
CHECK VALVE DISC	SS - 304	SS - 316	SS - 304	SS - 316
CHECK VALVE SEAT	NBR / VITON	NBR / VITON	NBR / VITON	NBR / VITON
DIFFUSER CHAMBER	SS - 304	SS - 316	SS - 304	SS - 316
IMPELLER	SS - 304	SS - 316	SS - 304	SS - 316
SPLIT CONE WITH NUT**	SS - 304	SS - 316	SS - 304	SS - 316
IMPELLER WEAR RING / SEAL RING	NBR / VITON	NBR / VITON	NBR / VITON	NBR / VITON
UPTHRUST WASHER / STOP RING	SS - 304 / TEFLON SS - 420 / BRONZE	SS - 316 / TEFLON	SS - 420 / CARBON	SS - 329 / CARBON
INTERMEDIATE BEARING	NBR / VITON	NBR / VITON	NBR / VITON	NBR / VITON
SUCTION INTER CONNECTOR	SS - 304	SS - 316	SS - 304	SS - 316
INLET SCREEN	SS - 304	SS - 316	SS - 304	SS - 316
PUMP SHAFT	SS - 304 / 431*	SS - 316 / 329*	SS - 431	SS - 329
COUPLING SPLINES	SS - 329	SS - 329	SS - 329	SS - 329
LOCKING STRAPS	SS - 304	SS - 316	SS - 304	SS - 316
CABLE GUARD	SS - 304	SS - 316	SS - 304	SS - 316

\* Provided only for 4", 14m<sup>3</sup>/h

\*\* Applicable for 4", 14m<sup>3</sup>/h and 6" 14m<sup>3</sup> to 60m<sup>3</sup>/h pump models.

Note : 4" 1m<sup>3</sup>/h to 8m<sup>3</sup>/h pumps are provided with hexagonal shaft and other 4" & 6" pumps are with round shaft.  
VITON Components are optional

For SS 316 construction replace the model third digit 'S' with 'N'



# 4" GP SERIES PUMPS

## CROSS SECTIONAL DRAWING - 4"

1 - 5 m<sup>3</sup>/h

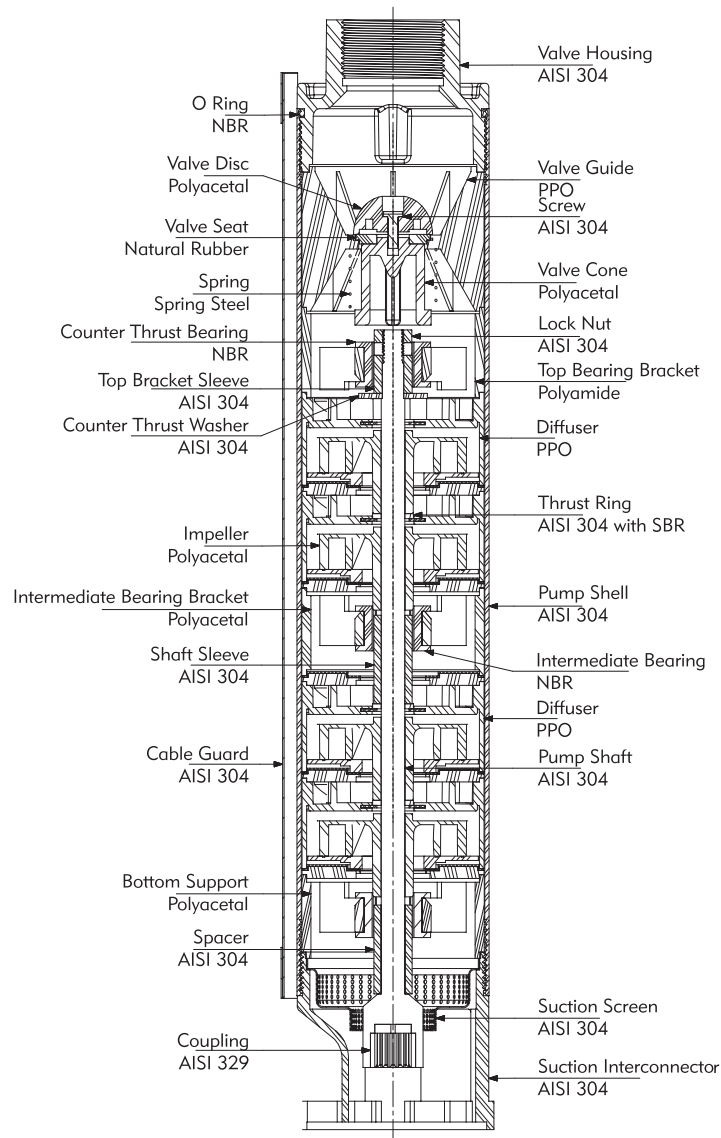

# 4" GP SERIES PUMPS

## CROSS SECTIONAL DRAWING - 4"

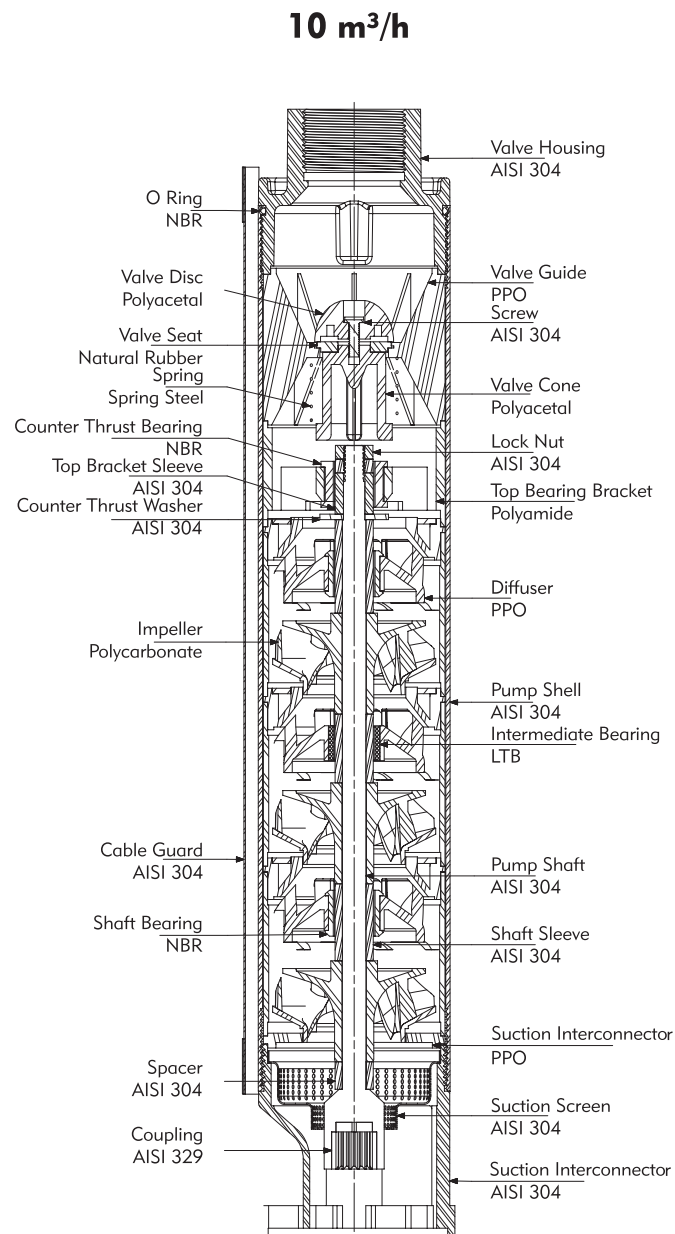

# 4" GP SERIES PUMPS

## CROSS SECTIONAL DRAWING - 4"

14 / 18 m<sup>3</sup>/h

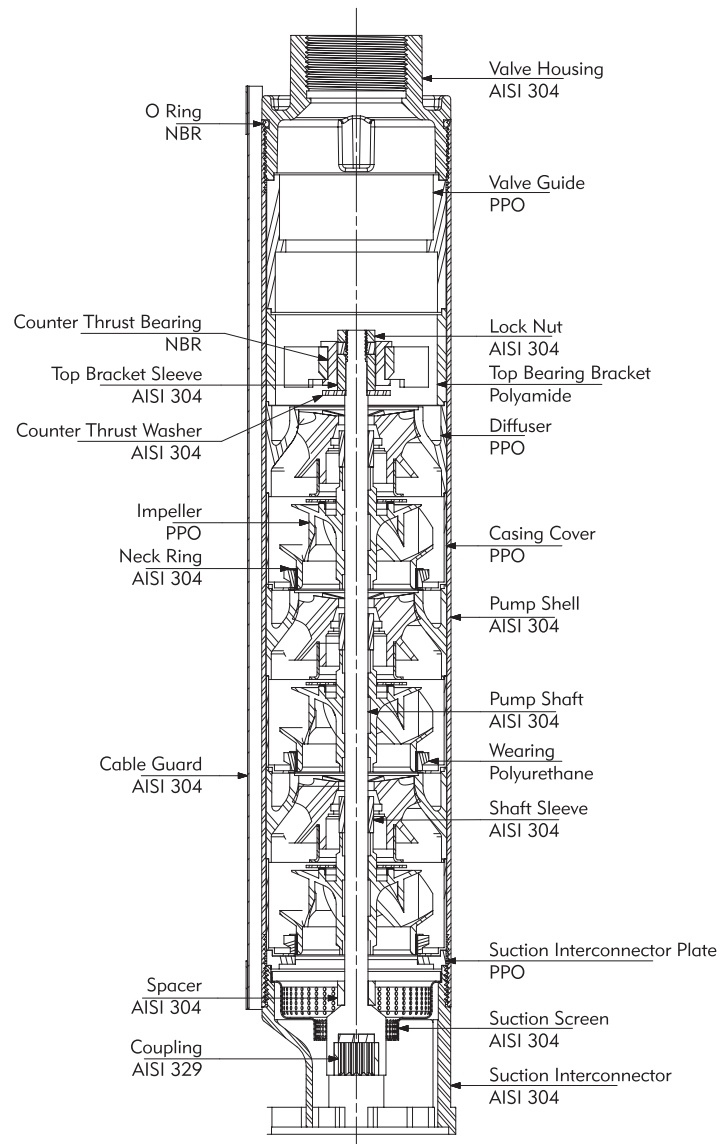

# 4" GS SERIES PUMPS

## CROSS SECTIONAL DRAWING - 4"

### 1 - 3m<sup>3</sup>/h and 5m<sup>3</sup>/h Lower Stage Assembly

1 - 3m<sup>3</sup>/h Upto 29 Stage and 5m<sup>3</sup>/h Upto 25 Stage

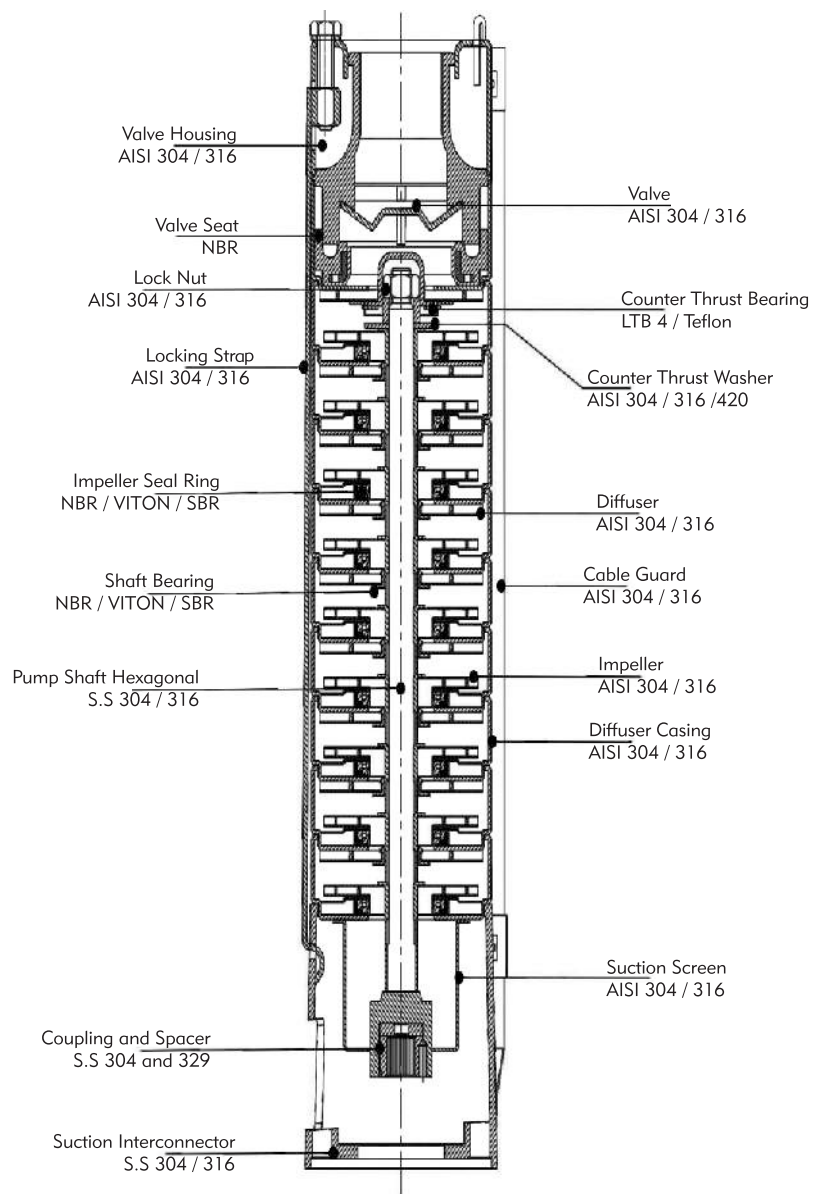

# 4" GS SERIES PUMPS

## CROSS SECTIONAL DRAWING - 4"

### 5m<sup>3</sup>/h and 8m<sup>3</sup>/h Higher Stage Assembly

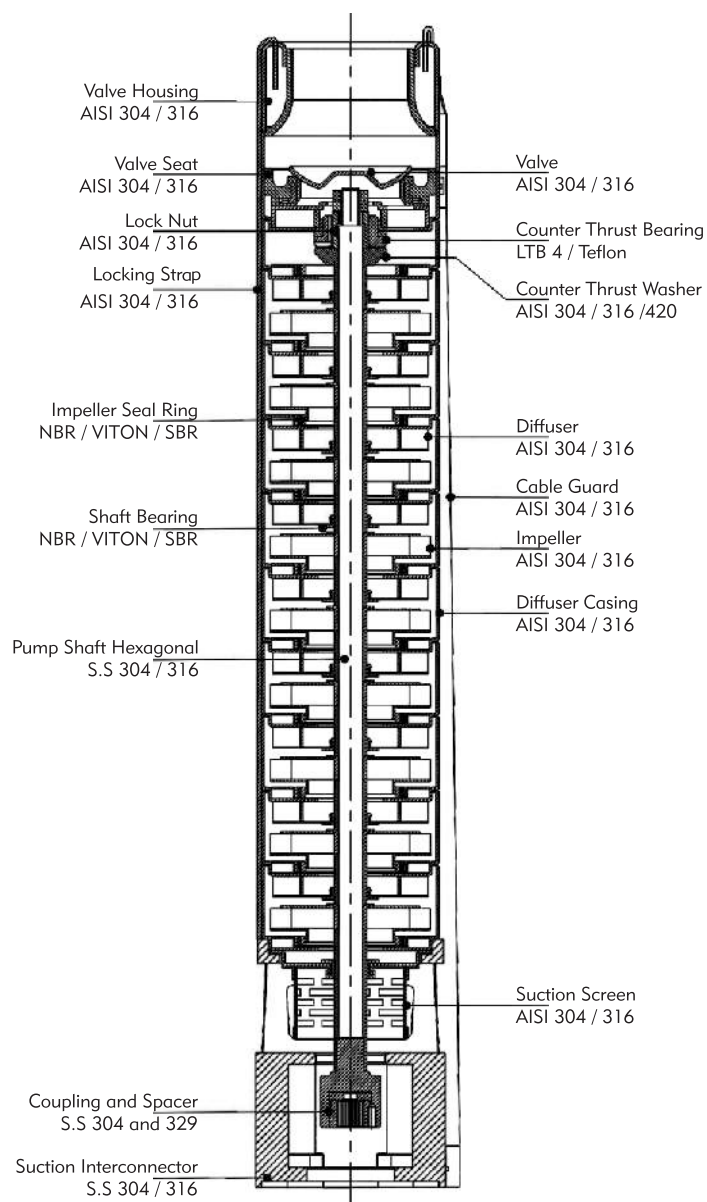

# 4" GS SERIES PUMPS

## CROSS SECTIONAL DRAWING - 4"

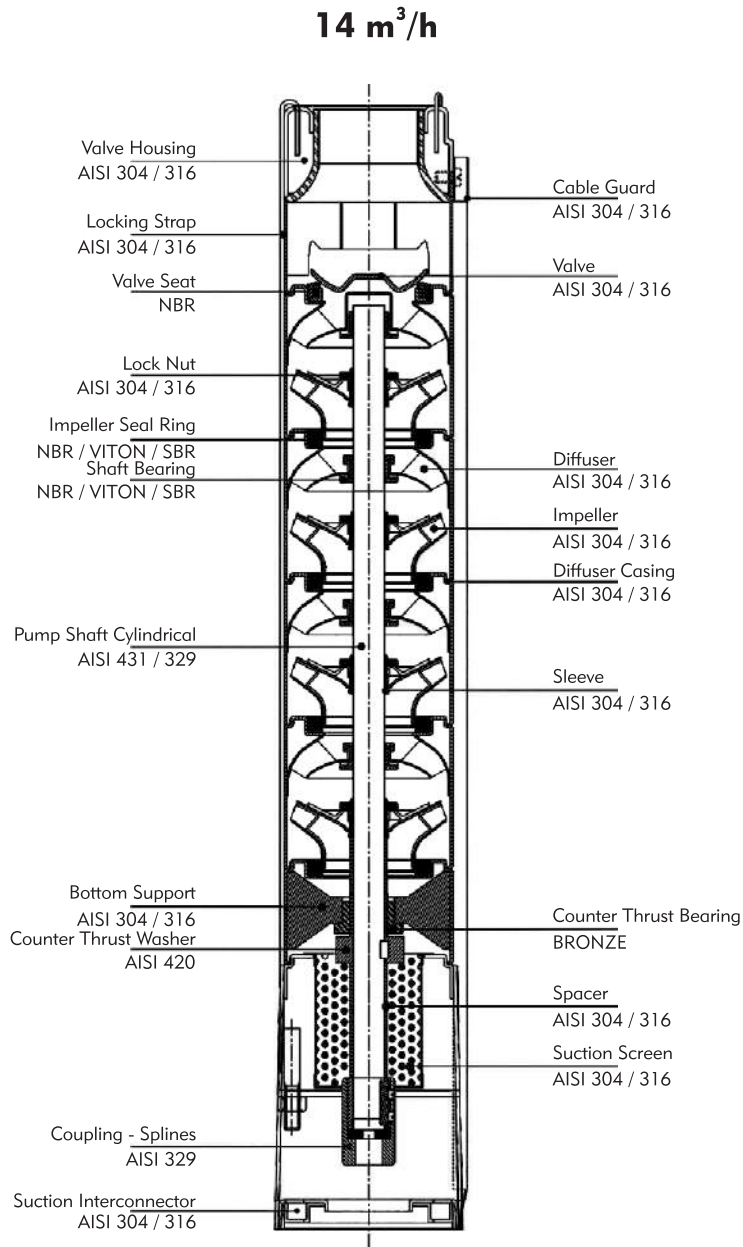

# 6" GS SERIES PUMPS

## CROSS SECTIONAL DRAWING - 6"

14 - 22 m<sup>3</sup>/h

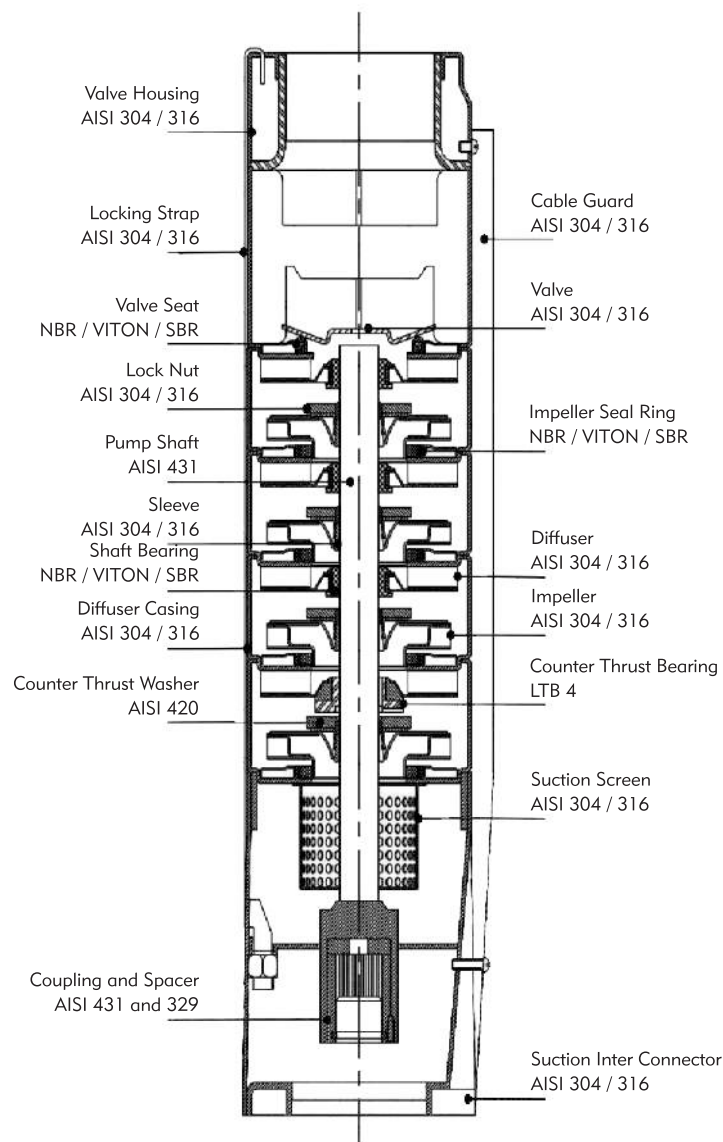

In View of Continuous Development, The Information / Description / Specification / Illustrations Are Subject to Change Without Notice.

# 6" GS SERIES PUMPS

## CROSS SECTIONAL DRAWING - 6"

30 - 60 m<sup>3</sup>/h

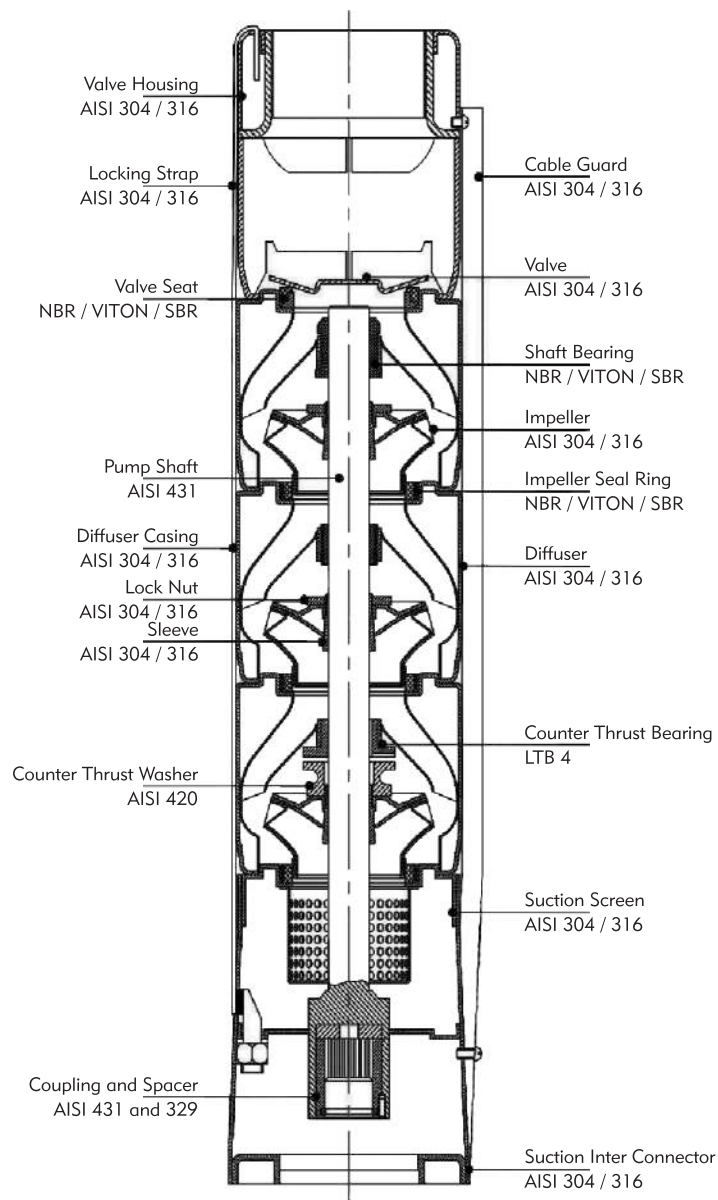



# 8" GS SERIES PUMPS

## CROSS SECTIONAL DRAWING - 8"

78 / 95 m<sup>3</sup>/h

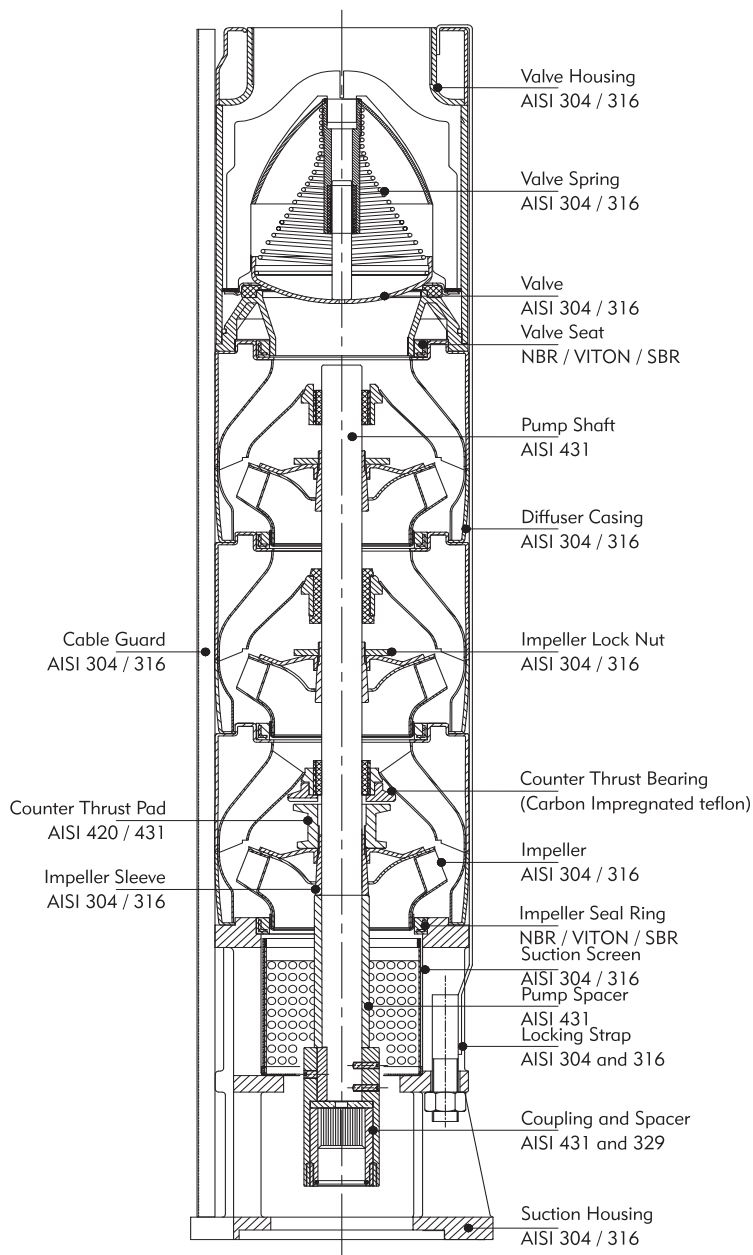

# 10" GS SERIES PUMPS

## CROSS SECTIONAL DRAWING - 10"

125, 160 & 215m<sup>3</sup>/h

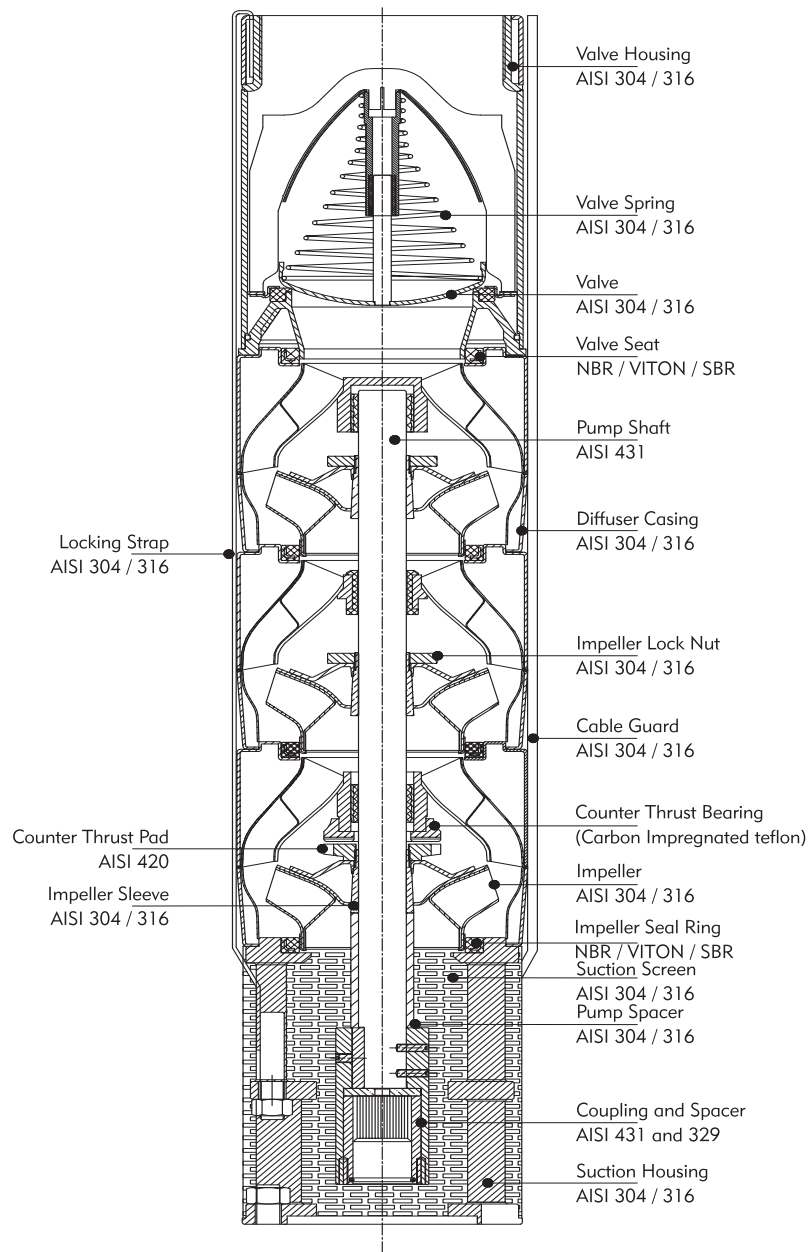

## GP SERIES PUMPS

### PUMPED LIQUIDS

Clean, Non-aggressive, Clear, Cold water without abrasives, solid particles or fibre having the following characteristics.

a)	<b>Temperature (max)</b>	33°C (max.)
b)	<b>Permissible amount of sand</b>	3" - 25 g/m <sup>3</sup> (max), 4" - 50 g/m <sup>3</sup>
c)	<b>Chlorine ion density</b>	500 ppm (max)
d)	<b>Allowable solids</b>	3000 ppm (max)
e)	<b>Specific gravity</b>	1.004 (max)
f)	<b>Hardness (Drinking water)</b>	300 (max)
g)	<b>Viscosity</b>	1.75 x 10 <sup>-6</sup> m <sup>2</sup> /sec (max)
h)	<b>Turbidity</b>	50 ppm silica scale (max)
i)	<b>pH</b>	6.5 to 8.5

PUMP OPERATING LIMITATIONS			
Nominal Diameter		3"(80mm)	4"(100mm)
Power Range		0.25 - 1.1 kW	0.37 - 7.5 kW
Speed		2850 rpm	2900 rpm
Discharge Range	m <sup>3</sup> /h	0.6 - 3	0.75 - 24
	lps	0.16 - 0.83	0.20 - 6.66
Total head range	m	8 - 138	4.0 - 250
	ft	26 - 453	13.0 - 820
Outlet size in inches		1	1¼, 1½, & 2

#### Maximum temperature of Pumped liquid

Motor	Minimum cooling flow along the motor	Vertical installation	Horizontal installation (minimum 30°angle)
3" & 4"	0.15 m/s	33°C	33°C

Maximum operating pressure	
3" Submersible pump	1.4 Mpa (14 bar)
4" Submersible pump	2.5 Mpa (25 bar)

# GP SERIES PUMPS

## MATERIAL OF CONSTRUCTION

PART NAME	NOMINAL DIA. 3"	NOMINAL DIA . 4"
	TYPE - P	TYPE - P
CHECK VALVE HOUSING	S.S - 304	S.S. - 304
CHECK VALVE	THERMO PLASTIC (POM)	DELTRIN
CHECK VALVE SEAT	THERMO PLASTIC (POM)	NBR
OUTER SHELL	S.S - 304	S.S. - 304
IMPELLER	THERMO PLASTIC (PPO)	NORYL*/ DELTRIN/ LEXAN**
DIFFUSER CHAMBER	THERMO PLASTIC (POM)	NORYL*/ LEXAN**
STOP RING	S.S - 304	HYLEM
INTERMEDIAR BEARING (SLEEVE / BUSH)	NBR	S.S. - 304 / NBR BRONZE
SUCTION INTER CONNECTOR	S.S - 304	S.S. - 304
INLET SCREEN	S.S. - 304	S.S. - 304
PUMP SHAFT HEXAGONAL	S.S. - 431	S.S. - 431
CABLE GUARD	S.S. - 304	S.S. - 304
*COUPLING SPLINES	S.S. - 329	S.S. - 329

\*Friction welded with shaft

### 3" GP SERIES PUMPS

Nominal Diameter : 3"    Nominal Flow : 1.8 m<sup>3</sup>/h    Outlet Size : 1"

### PERFORMANCE CURVES

Flow Range : 0.6 - 3.0 m<sup>3</sup>/h

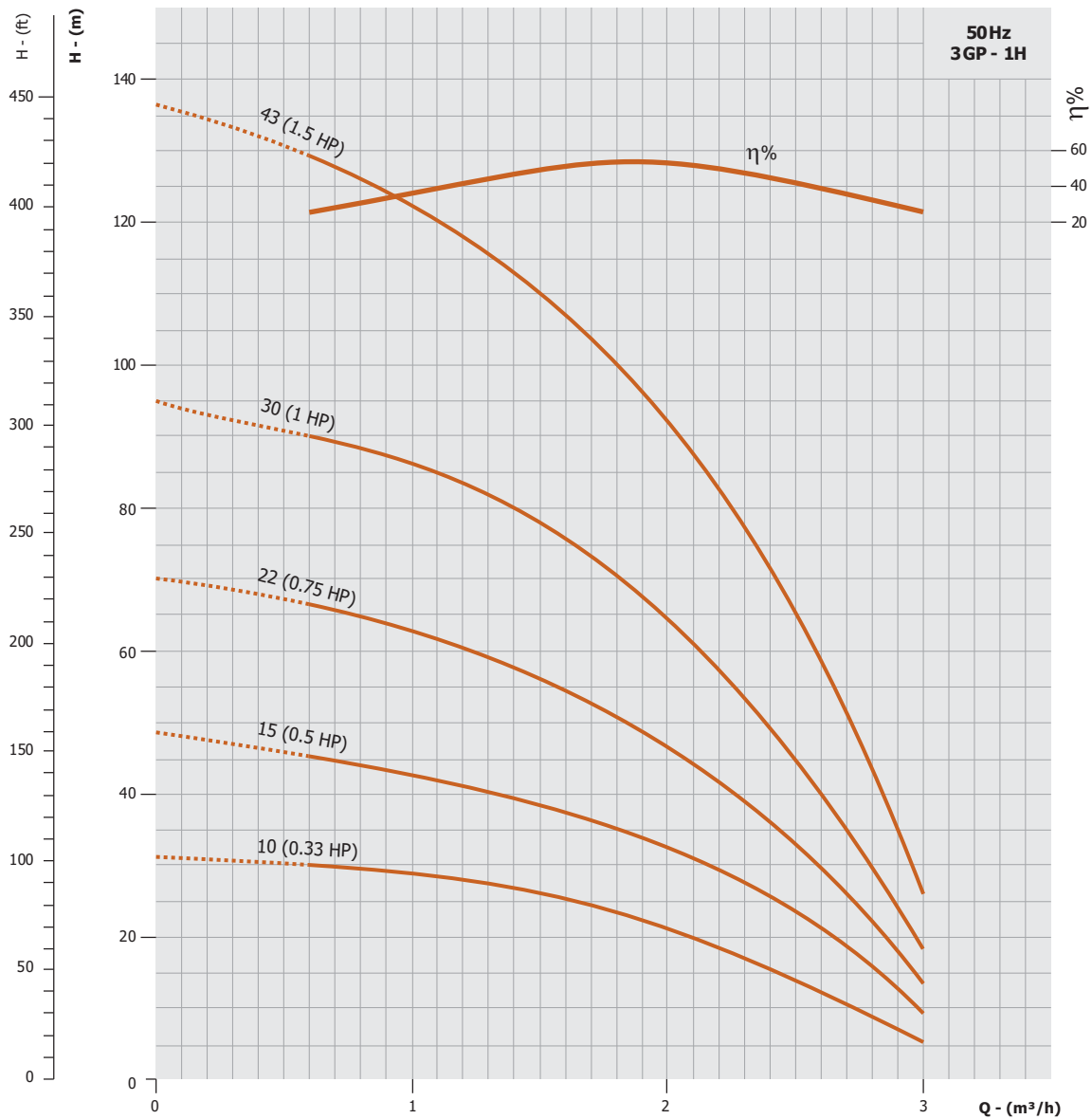

## 3" GP SERIES PUMPS

Nominal Diameter : 3"    Nominal Flow : 1.8 m<sup>3</sup>/h    Outlet Size : 1"

### HEIGHT & WEIGHT TABLE

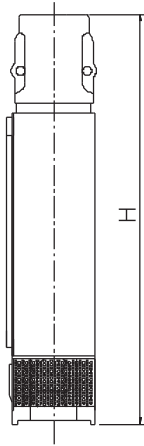

PUMP MODEL	HEIGHT (mm)	APPROX NETT. WEIGHT (kg)
3GP - 1H/10	454	2.5
3GP - 1H/15	601	3.5
3GP - 1H/22	777	4.2
3GP - 1H/30	998	5.5
3GP - 1H/43	1388	7.0

# 4" GP SERIES - FLOATING IMPELLER MODEL PUMPS

Nominal Diameter : 4"    Nominal Flow : 1.5 m<sup>3</sup>/h    Outlet Size : 1 1/4"

## PERFORMANCE CURVES

Flow Range : 0.75 - 2.1 m<sup>3</sup>/h

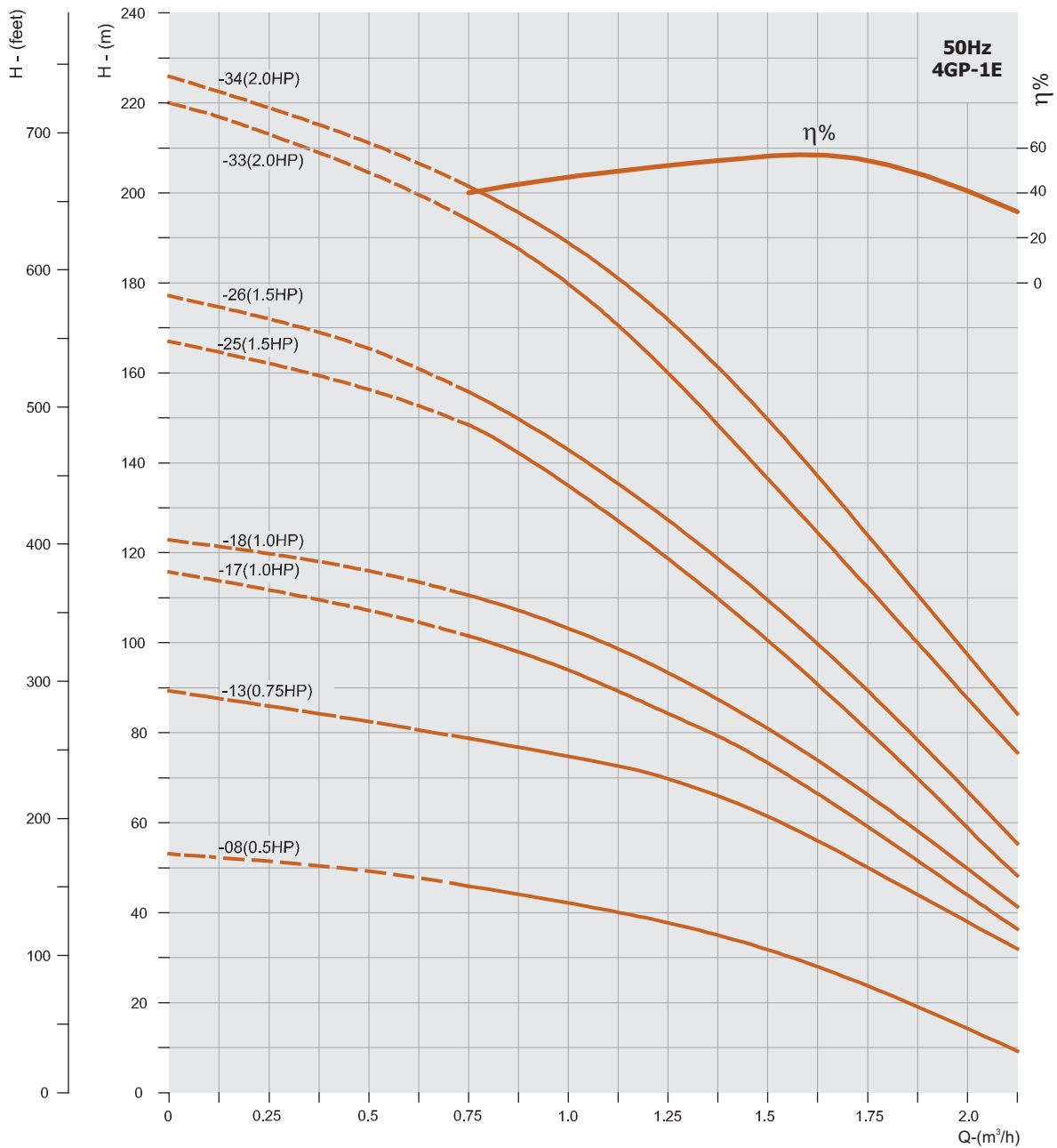

# 4" GP SERIES - FLOATING IMPELLER MODEL PUMPS

Nominal Diameter : 4"

Nominal Flow : 2 m<sup>3</sup>/h

Outlet Size : 1 1/4"

## PERFORMANCE CURVES

Flow Range : 1.1 - 3 m<sup>3</sup>/h

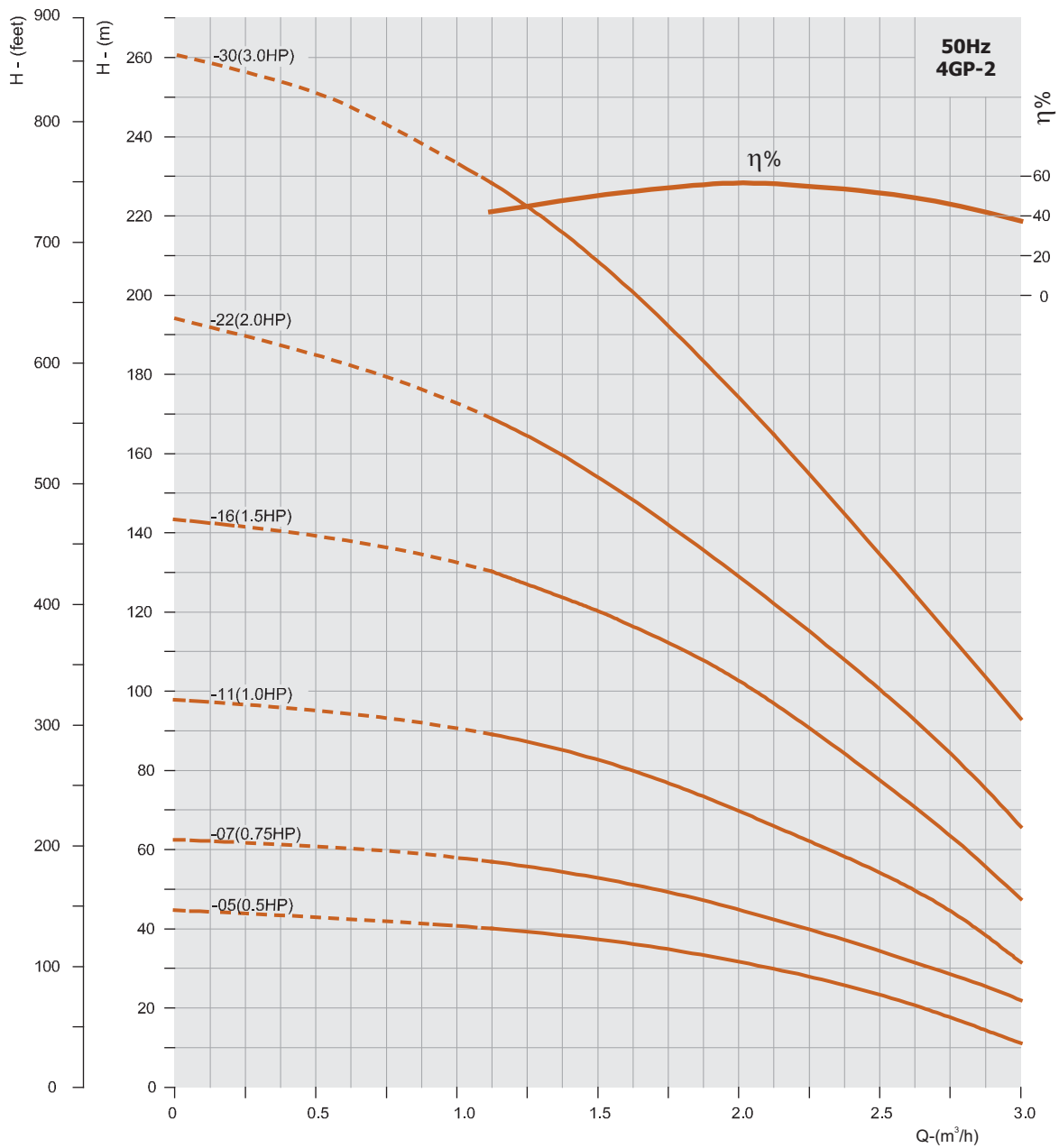



# 4" GP SERIES - FLOATING IMPELLER MODEL PUMPS

Nominal Diameter : 4"    Nominal Flow : 3 m<sup>3</sup>/h    Outlet Size : 1 1/4"

## PERFORMANCE CURVES

Flow Range : 1.75 - 5 m<sup>3</sup>/h

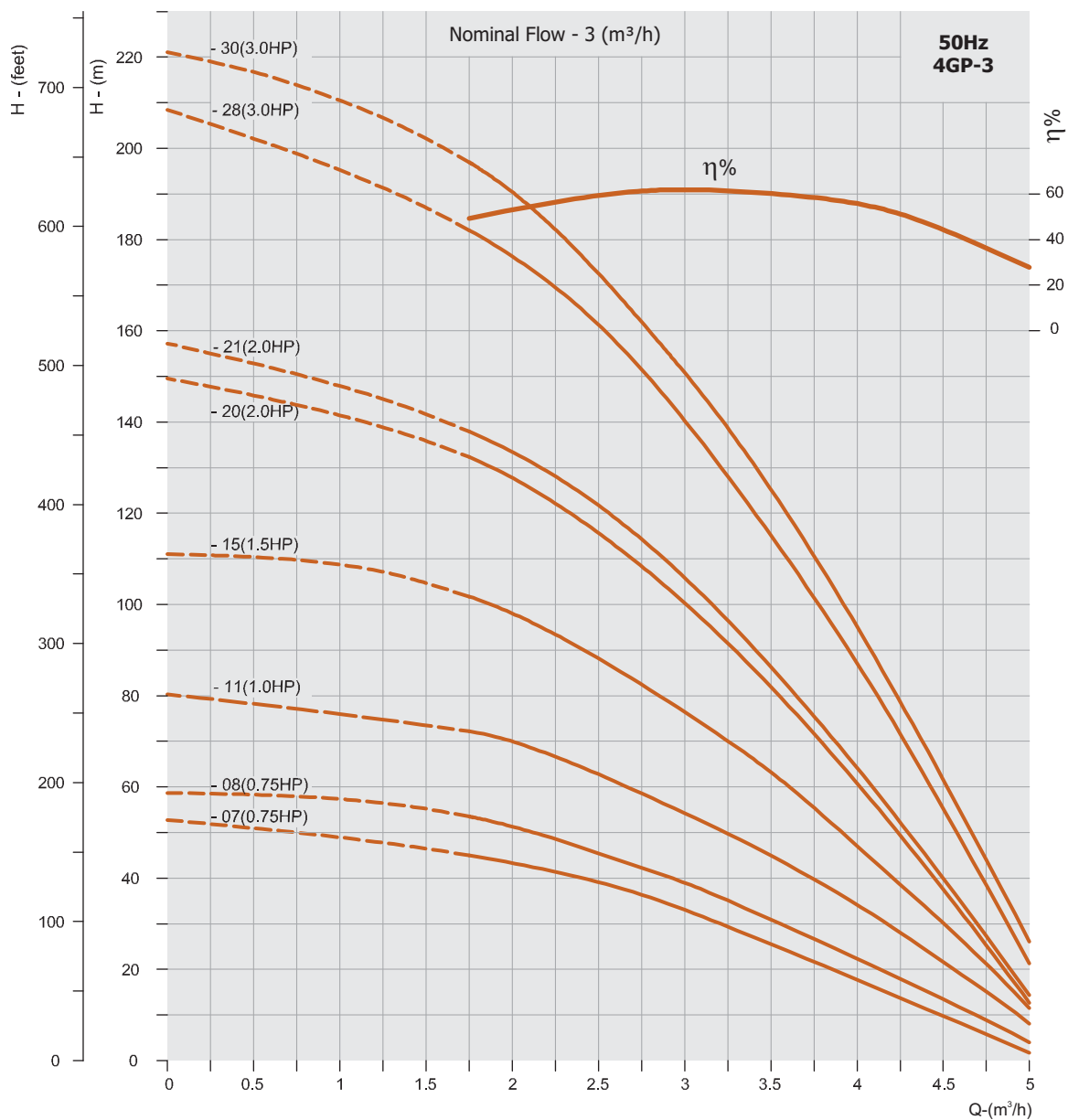

# 4" GP SERIES - FLOATING IMPELLER MODEL PUMPS

Nominal Diameter : 4"    Nominal Flow : 4 m<sup>3</sup>/h    Outlet Size : 1 1/4"

## PERFORMANCE CURVES

Flow Range : 2.5 - 6.5 m<sup>3</sup>/h

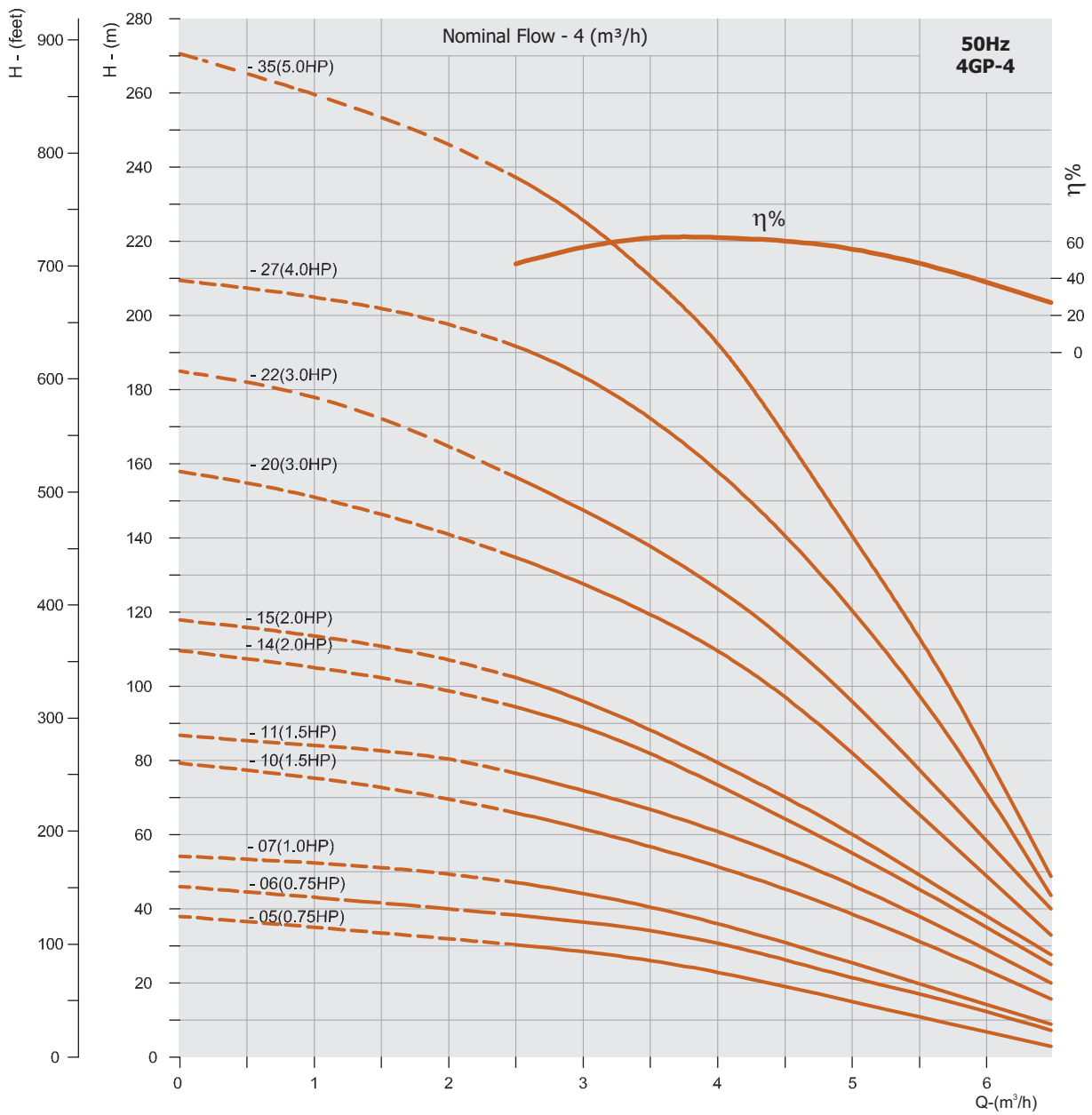

# 4" GP SERIES - FLOATING IMPELLER MODEL PUMPS

Nominal Diameter : 4"    Nominal Flow : 5 m<sup>3</sup>/h    Outlet Size : 1½"

## PERFORMANCE CURVES

Flow Range : 3 - 8 m<sup>3</sup>/h

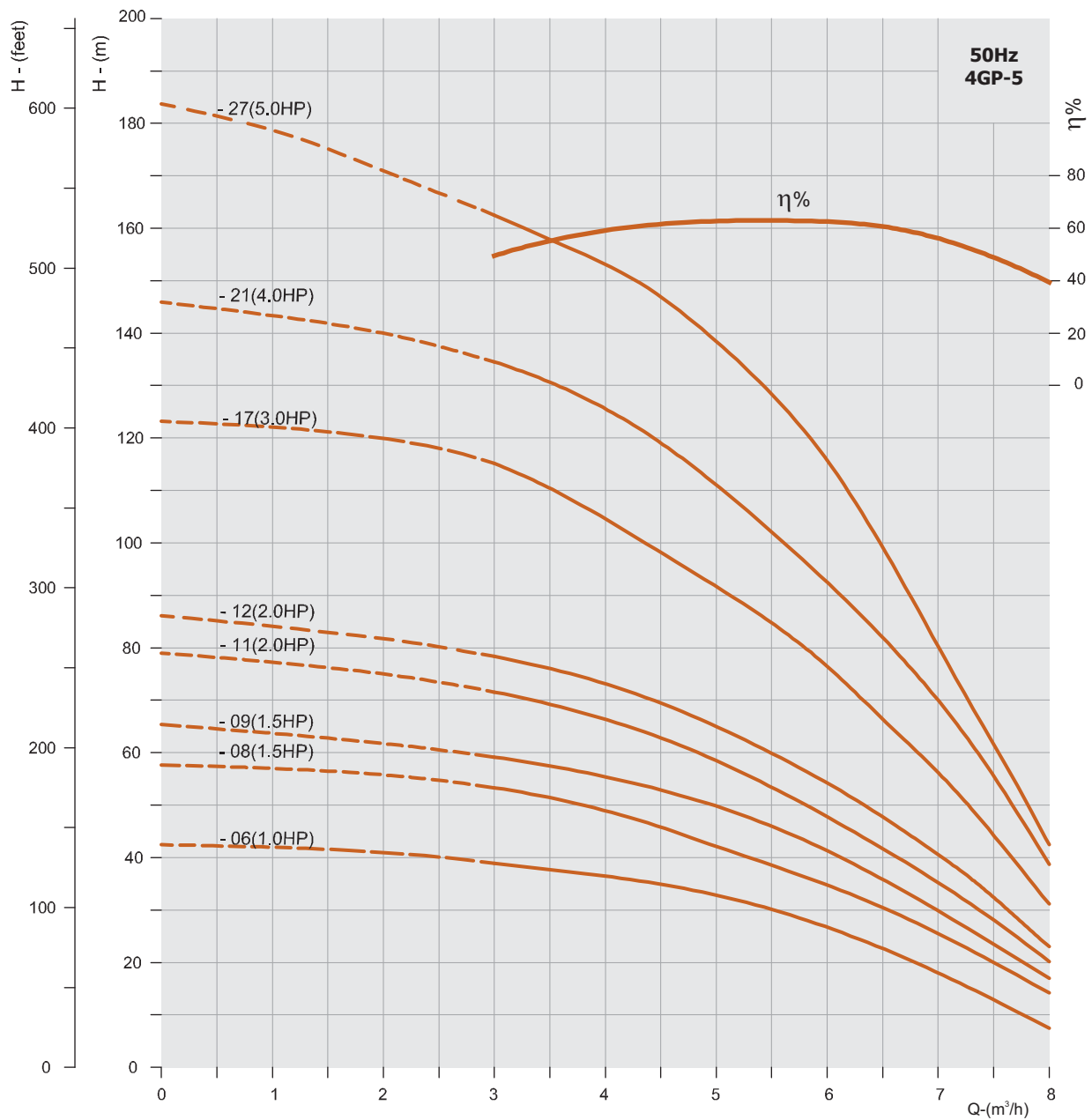

# 4" GP SERIES PUMPS

Nominal Diameter : 4"

Nominal Flow : 8 m<sup>3</sup>/h

Outlet Size : 2"

## PERFORMANCE CURVES

Flow Range : 4 - 12 m<sup>3</sup>/h

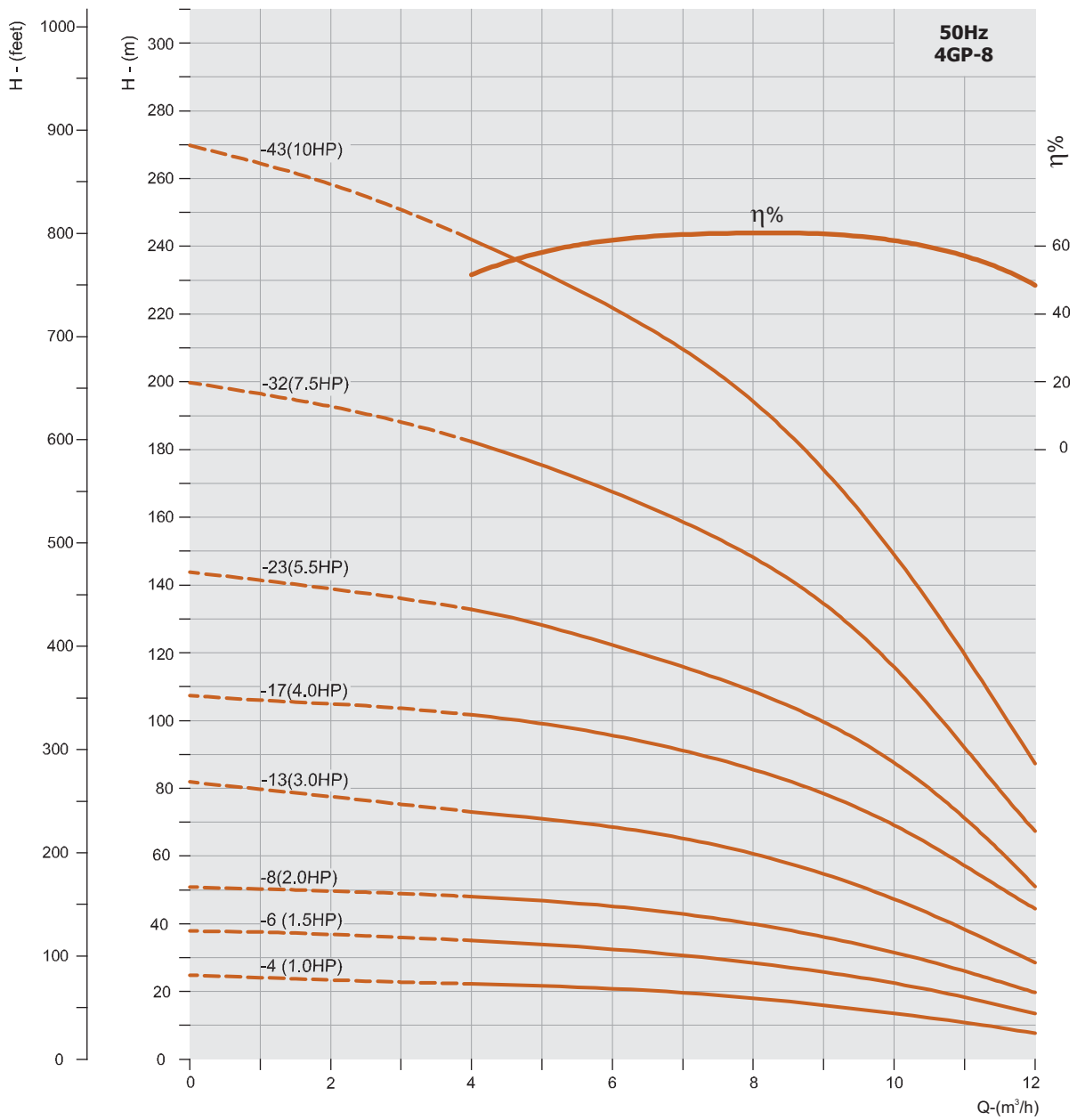

# 4" GP SERIES PUMPS

Nominal Diameter : 4"    Nominal Flow : 10 m<sup>3</sup>/h    Outlet Size : 2"

## PERFORMANCE CURVES

Flow Range : 6 - 15 m<sup>3</sup>/h

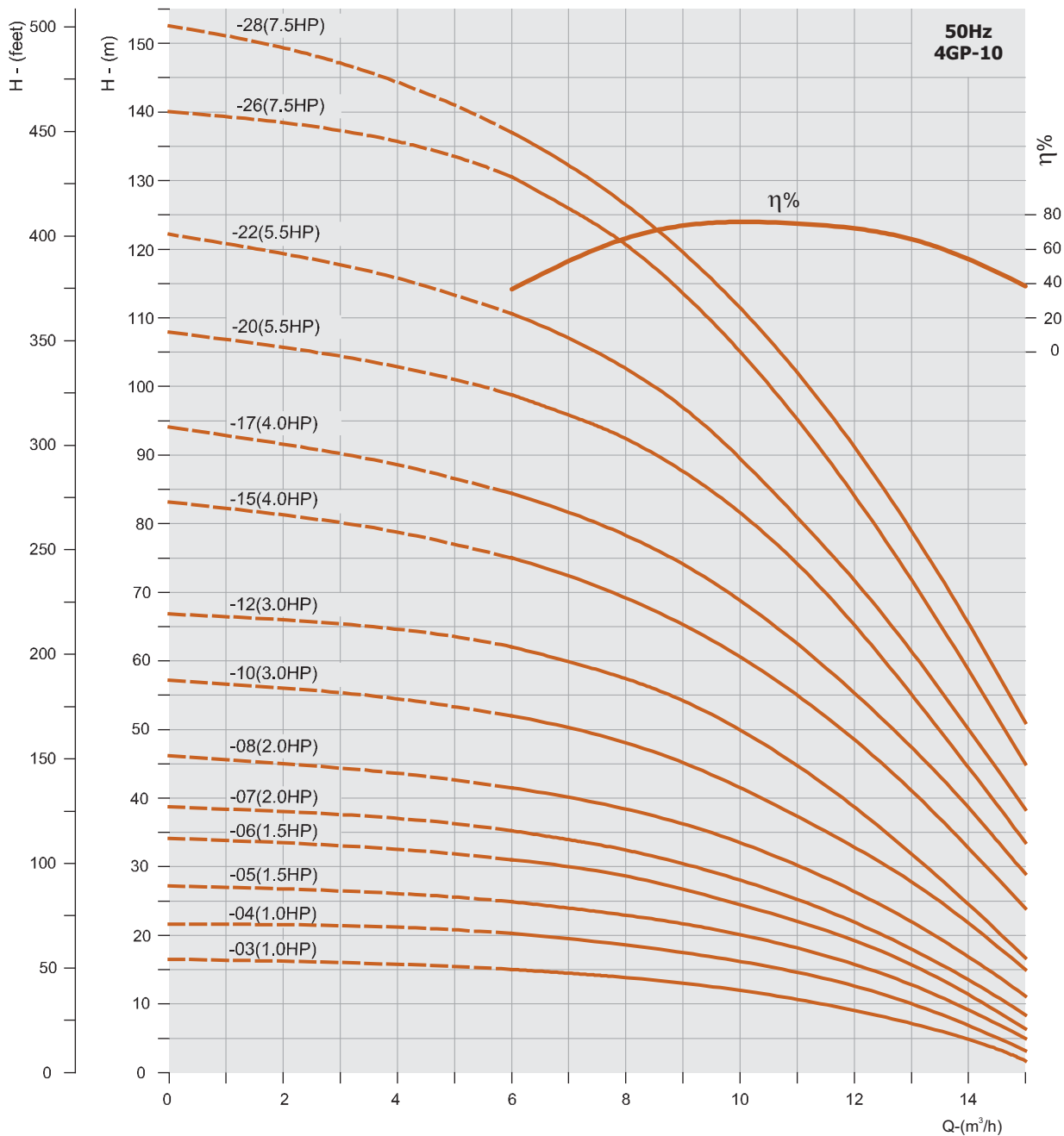

# 4" GP SERIES PUMPS

Nominal Diameter : 4"    Nominal Flow : 14 m<sup>3</sup>/h    Outlet Size : 2"

## PERFORMANCE CURVES

Flow Range : 8.0 - 20 m<sup>3</sup>/h

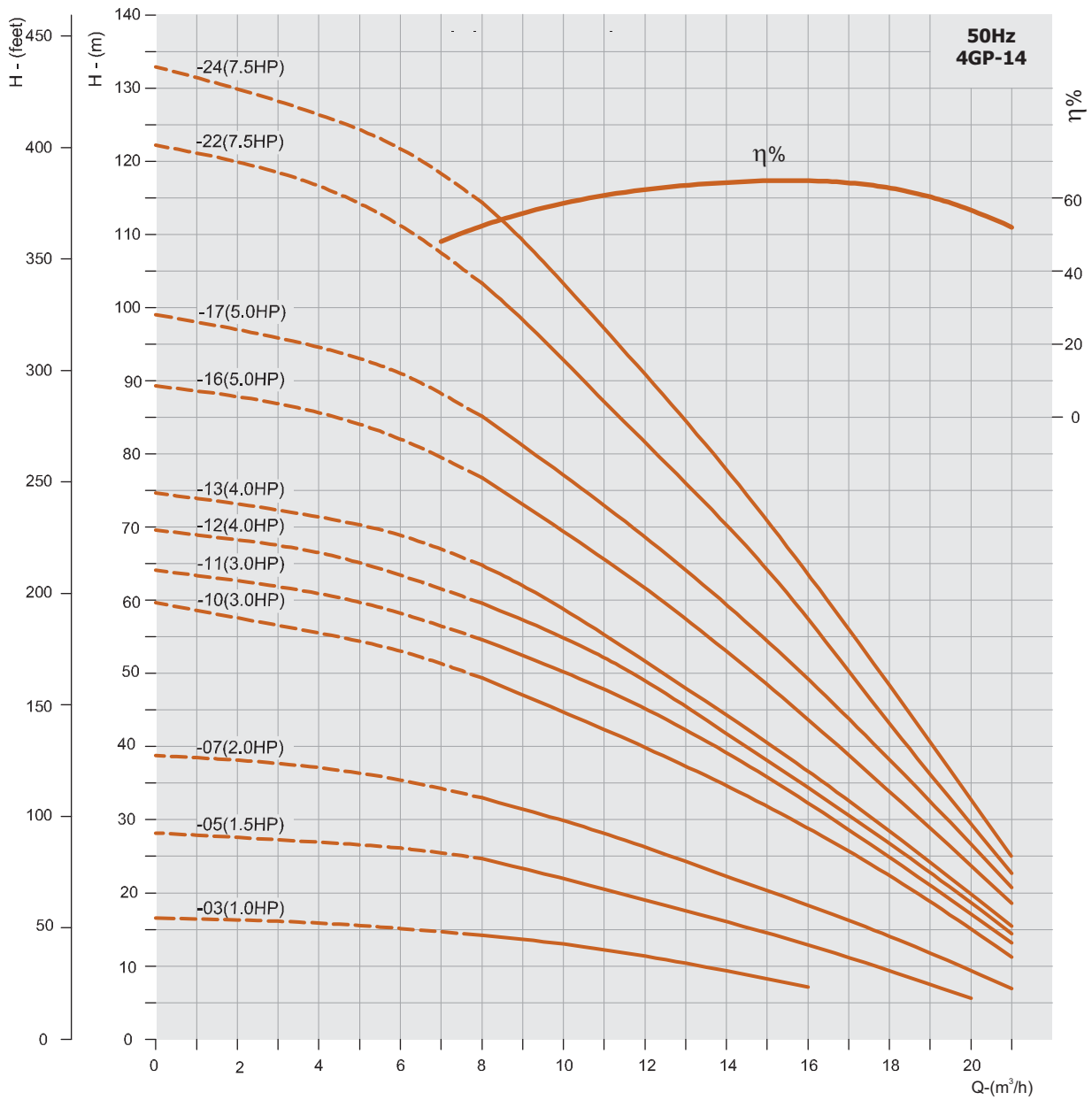

# 4" GP SERIES PUMPS

Nominal Diameter : 4"    Nominal Flow : 18 m<sup>3</sup>/h    Outlet Size : 2"

## PERFORMANCE CURVES

Flow Range : 9 - 24 m<sup>3</sup>/h

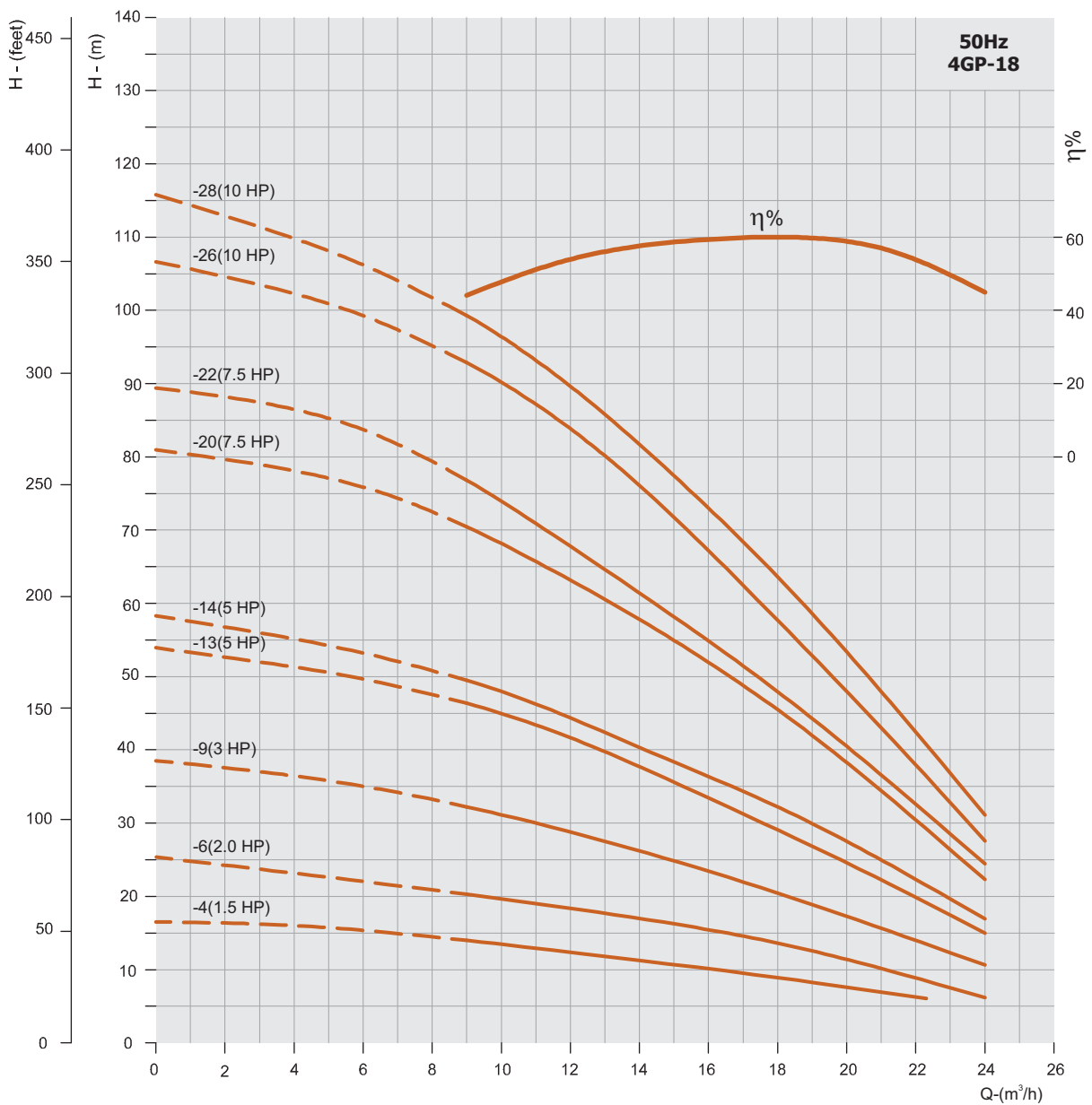

# 4" GP SERIES PUMPS

Nominal Diameter : 4"

## HEIGHT & WEIGHT TABLE

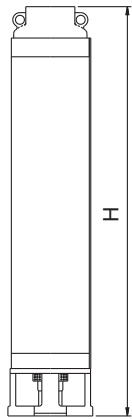

PUMP MODEL	HEIGHT (mm)	APPROX NETT. WEIGHT (kg)
4GP - 1E/08	44	3.3
4GP - 1E/13	524	4.2
4GP - 1E-17	654	5.0
4GP - 1E/18	679	5.3
4GP - 1E/25	860	8.8
4GP - 1E/26	882	9.0
4GP - 1E/33	1036	11.6
4GP - 1E/34	1058	12.0

PUMP MODEL	HEIGHT (mm)	APPROX NETT. WEIGHT (kg)
4GP - 2/05	354	2.8
4GP - 2/07	400	3.1
4GP - 2/11	493	3.8
4GP - 2/16	651	6.5
4GP - 2/22	790	7.7
4GP - 2/30	1006	10.5

PUMP MODEL	HEIGHT (mm)	APPROX NETT. WEIGHT (kg)
4GP - 3/07	426	2.8
4GP - 3/08	453	3.4
4GP - 3/11	533	3.9
4GP - 3/15	671	4.9
4GP - 3/20	818	7.9
4GP - 3/21	844	8.2
4GP - 3/28	1063	10.9
4GP - 3/30	1117	11.7

PUMP MODEL	HEIGHT (mm)	APPROX NETT. WEIGHT (kg)
4GP - 4/05	383	1.9
4GP - 4/06	412	2.4
4GP - 4/07	441	3.3
4GP - 4/10	528	4.0
4GP - 4/11	557	4.4
4GP - 4/14	674	5.6
4GP - 4/15	703	6.0
4GP - 4/20	860	8.0
4GP - 4/22	918	8.8
4GP - 4/27	1093	10.8
4GP - 4/35	1325	14.0

PUMP MODEL	HEIGHT (mm)	APPROX NETT. WEIGHT (kg)
4GP-5/06	459	3.4
4GP-5/08	533	3.0
4GP-5/09	570	3.5
4GP-5/11	643	4.3
4GP-5/12	680	4.8
4GP-5/17	907	6.6
4GP-5/21	1054	8.2
4GP-5/27	130	10.5



## 4" GP SERIES PUMPS

Nominal Diameter : 4"

### HEIGHT & WEIGHT TABLE

PUMP MODEL	HEIGHT (mm)	APPROX NETT. WEIGHT (kg)
4GP-8/04	374	3.8
4GP-8/06	436	4.4
4GP-8/08	498	3.2
4GP-8/13	653	6.5
4GP-8/17	807	7.9
4GP-8/23	993	10.0
4GP-8/32	1302	13.0
4GP-8/43	1643	17.5

PUMP MODEL	HEIGHT (mm)	APPROX NETT. WEIGHT (kg)
4GP-10/03	448	2.7
4GP-10/04	450	3.0
4GP-10/05	562	3.8
4GP-10/06	570	4.5
4GP-10/07	676	5.3
4GP-10/08	690	6.0
4GP-10/10	790	7.6
4GP-10/12	904	9.1
4GP-10/15	1075	11.3
4GP-10/17	1189	12.8
4GP-10/20	1360	15.0
4GP-10/22	1474	16.6
4GP-10/26	1702	19.6
4GP-10/28	1816	21.1

PUMP MODEL	HEIGHT (mm)	APPROX NETT. WEIGHT (kg)
4GP-14/03	463	2.6
4GP-14/05	610	4.3
4GP-14/07	775	6.0
4GP-14/10	1009	8.5
4GP-14/11	1087	9.7
4GP-14/12	1165	10.2
4GP-14/13	1243	11.0
4GP-14/16	1477	13.6
4GP-14/17	1555	14.4
4GP-14/22	1945	29.0
4GP-14/24	2101	33.0

PUMP MODEL	HEIGHT (mm)	APPROX NETT. WEIGHT (kg)
4GP-18/04	407	3.8
4GP-18/06	648	5.0
4GP-18/09	860	6.5
4GP-18/13	1142	9.8
4GP-18/14	1213	10.5
4GP-18/20	1637	15.5
4GP-18/22	1778	18.0
4GP-18/26	2060	19.1
4GP-18/28	2201	22.0

# 4" GS SERIES PUMPS

Nominal Diameter : 4"

Nominal Flow : 1 m<sup>3</sup>/h

Outlet Size : 1 1/4"

## PERFORMANCE CURVES

Flow Range : 0.4 - 1.7 m<sup>3</sup>/h

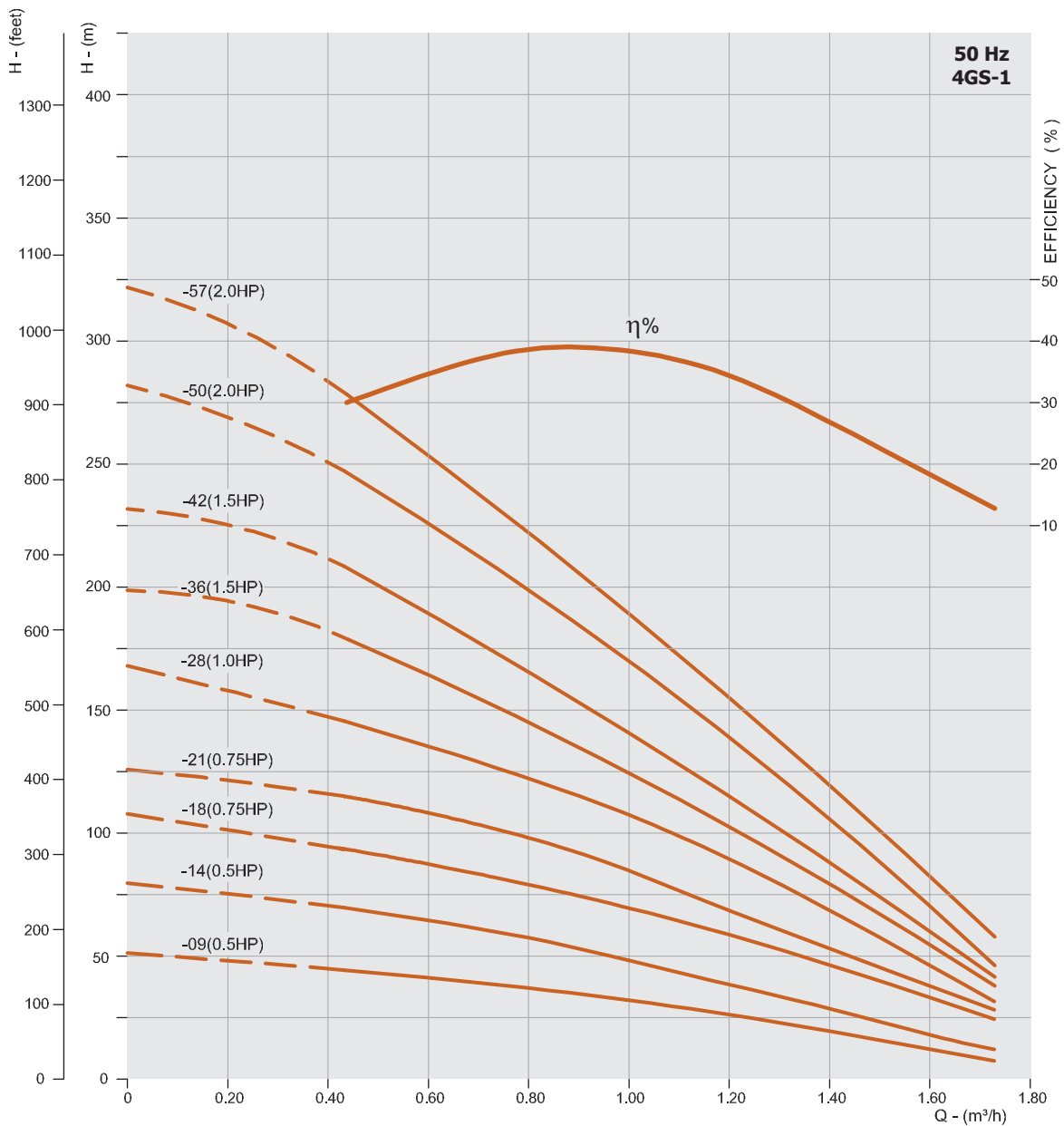

4" Sub OD for pumps with investment casting suction inter connector is 100mm

# 4" GS SERIES PUMPS

Nominal Diameter : 4" Nominal Flow : 2m<sup>3</sup>/h Outlet Size : 1 1/4"

## PERFORMANCE CURVES

Flow Range : 0.7 - 2.5 m<sup>3</sup>/h

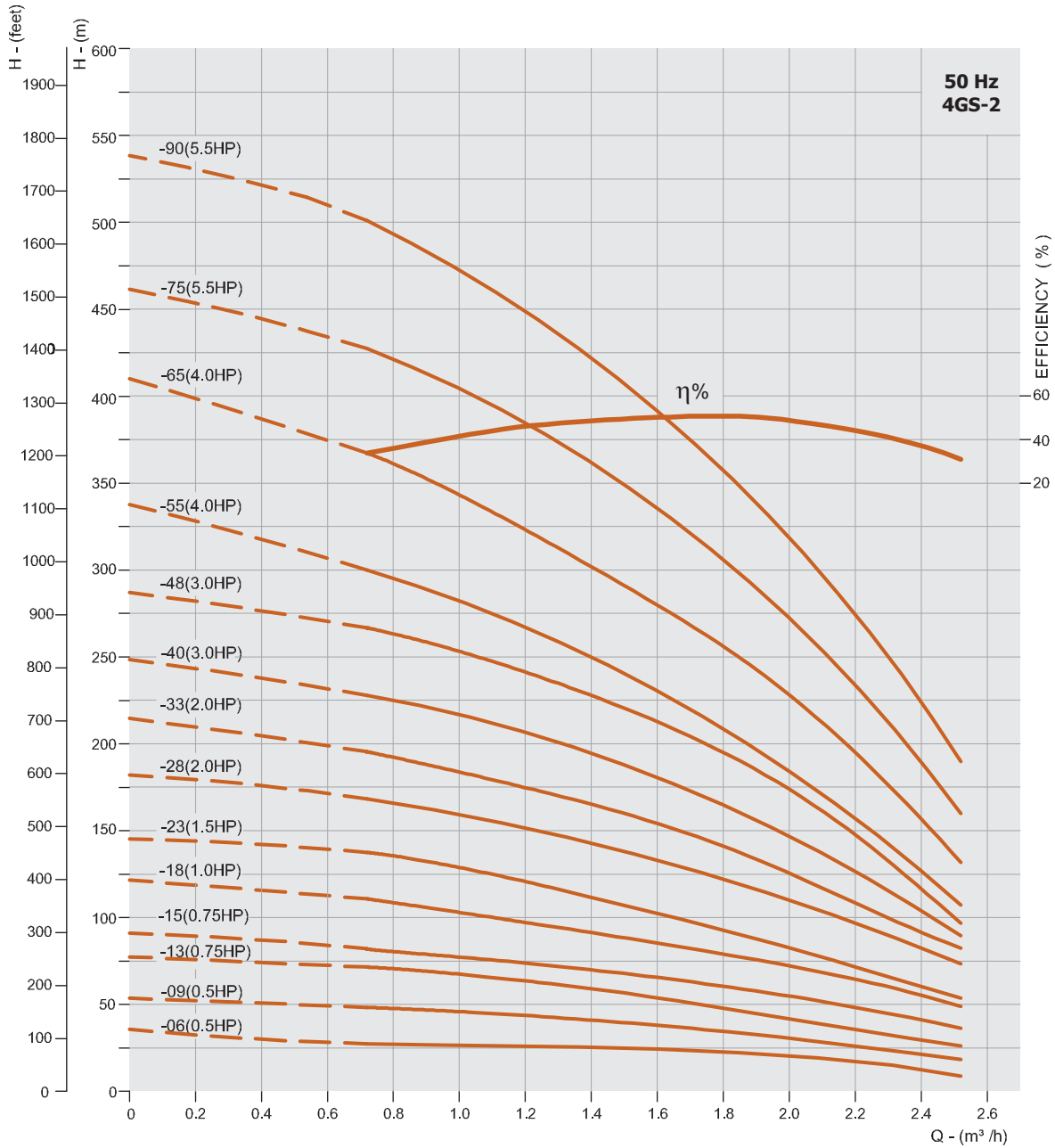

# 4" GS SERIES PUMPS

Nominal Diameter : 4"    Nominal Flow : 3m<sup>3</sup>/h    Outlet Size : 1 1/4"

## PERFORMANCE CURVES

Flow Range : .44 - 4.50 m<sup>3</sup>/h

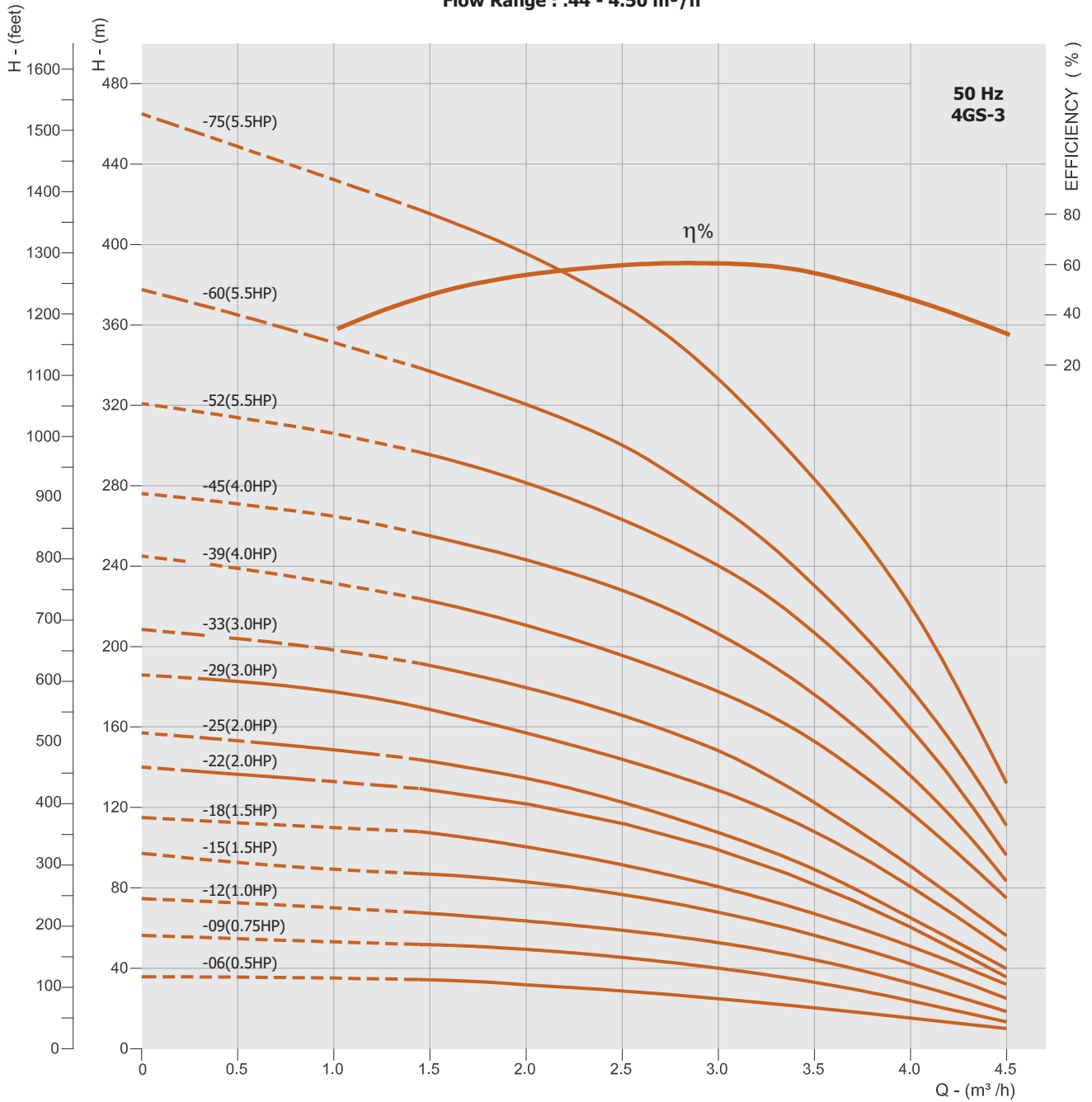

# 4" GS SERIES PUMPS

Nominal Diameter : 4" Nominal Flow : 5m<sup>3</sup>/h Outlet Size : 1½"

## PERFORMANCE CURVES

Flow Range : 2.2 - 7.5 m<sup>3</sup>/h

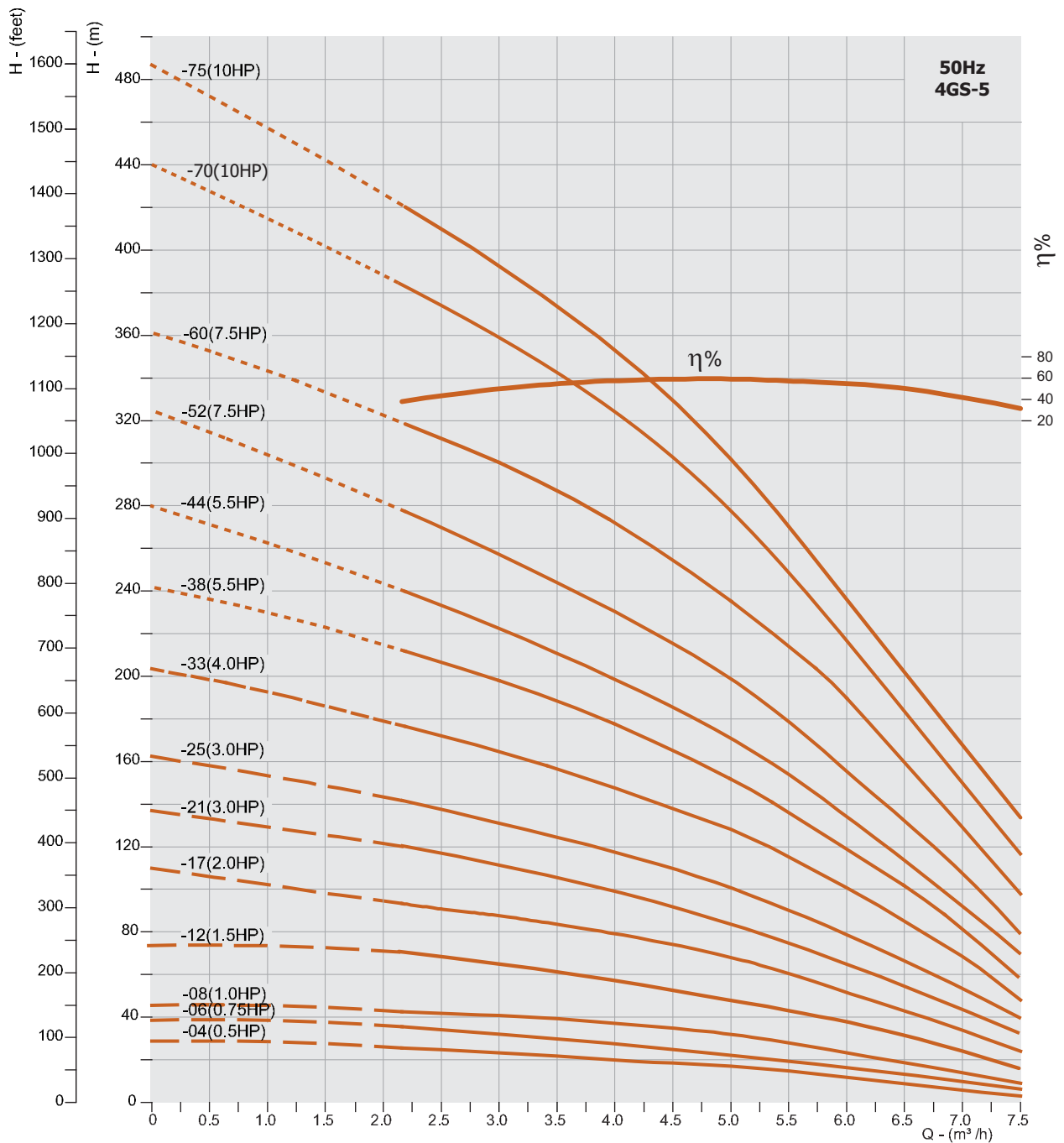

# 4" GS SERIES PUMPS

Nominal Diameter : 4"    Nominal Flow : 8m<sup>3</sup>/h    Outlet Size : 2"

## PERFORMANCE CURVES

Flow Range : 3.6 - 11.7 m<sup>3</sup>/h

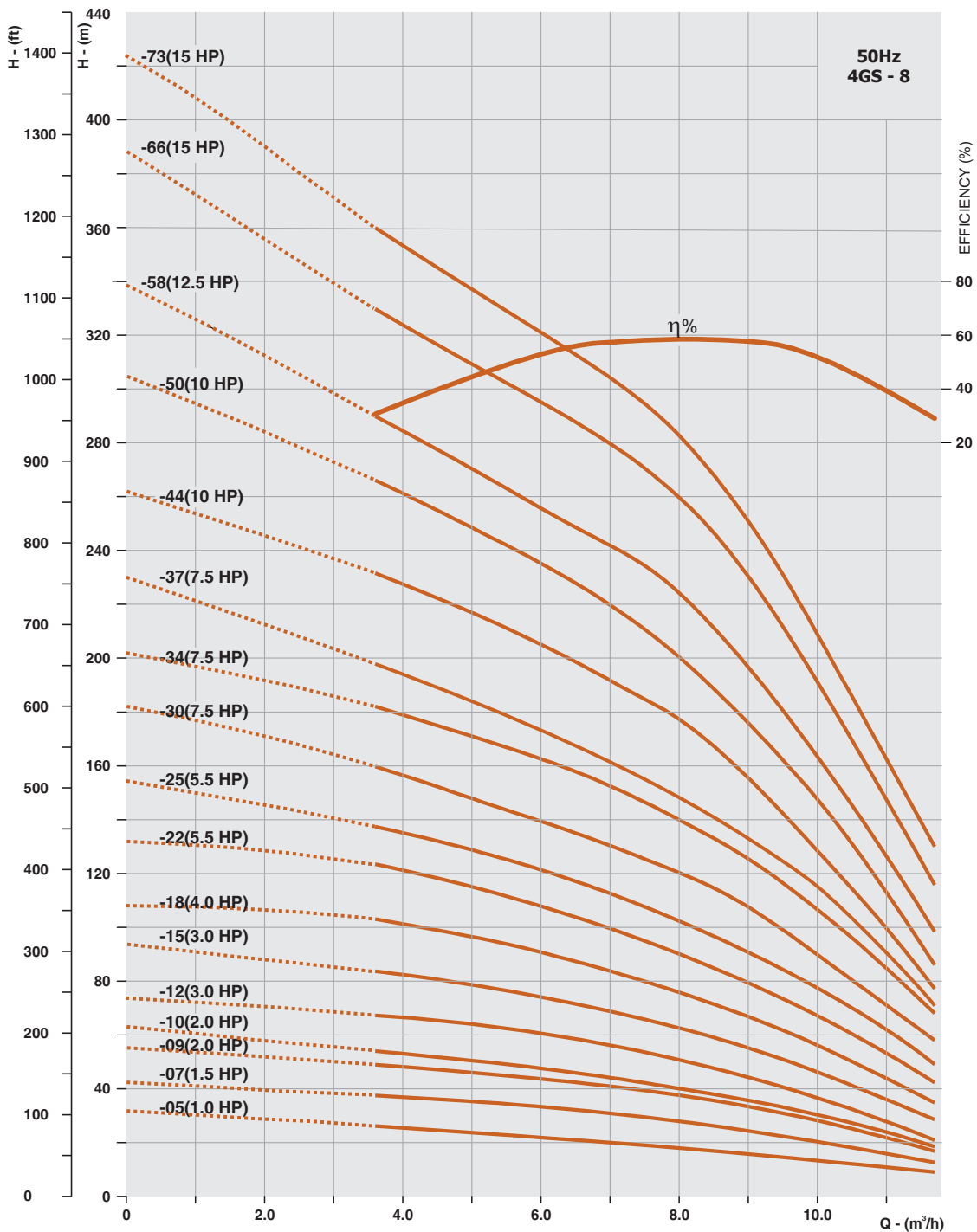

# 4" GS SERIES PUMPS

Nominal Diameter : 4" Nominal Flow : 14m<sup>3</sup>/h Outlet Size : 2"

## PERFORMANCE CURVES

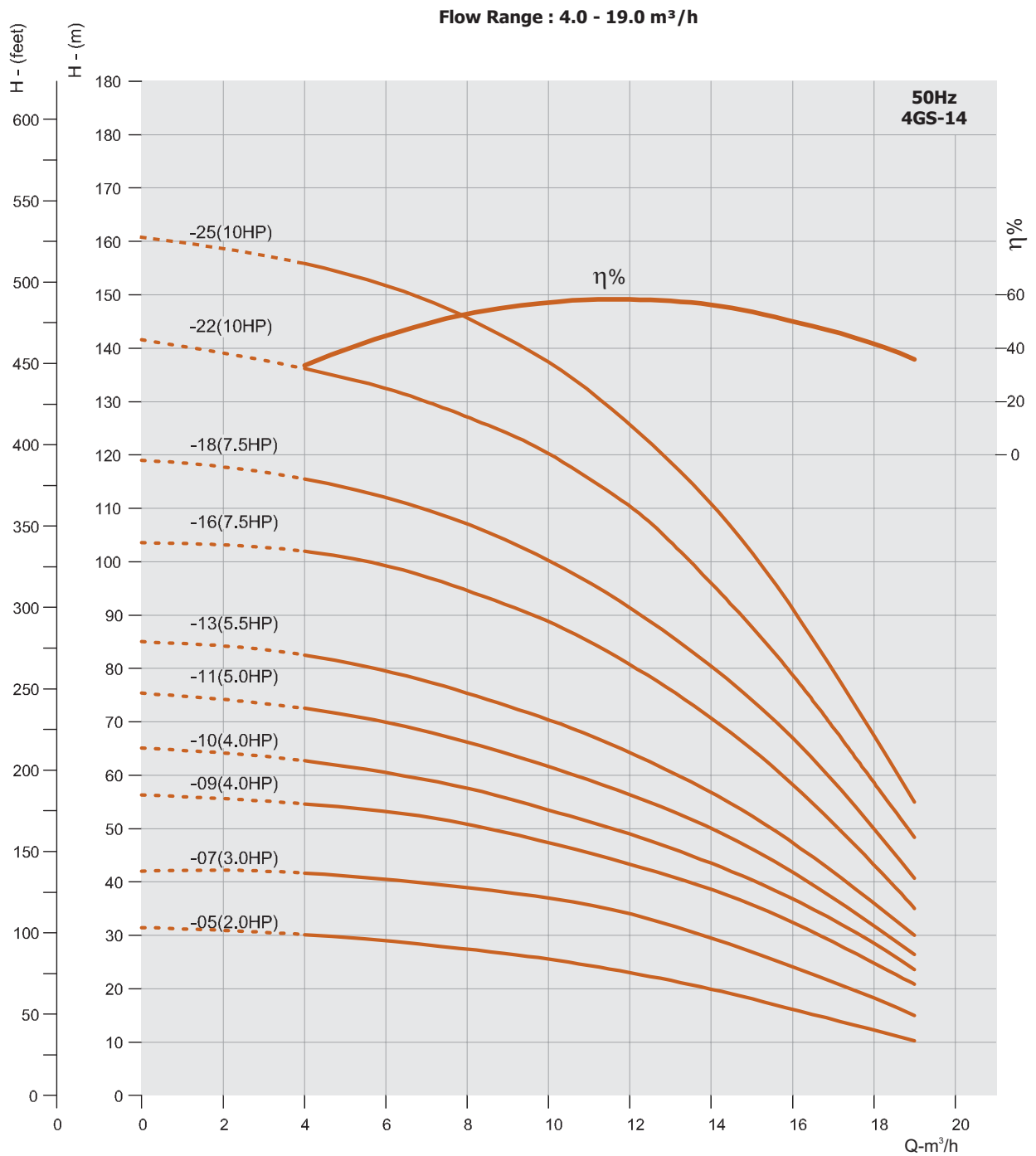

# 4" GS SERIES PUMPS

## HEIGHT & WEIGHT TABLE

HEIGHT & WEIGHT

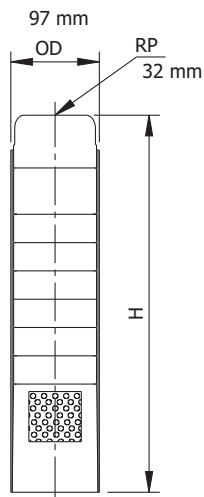

PUMP MODEL	HEIGHT (mm)	APPROX NETT. WEIGHT (kg)
4GS-1/09	357	3.75
4GS-1/14	467	4.79
4GS-1/18	555	6.15
4GS-1/21	621	7.25
4GS-1/28	775	9.40
4GS-1/36	1094	13.40
4GS-1/42	1262	16.45
4GS-1/50	1454	18.85
4GS-1/57	1646	21.00

PUMP MODEL	HEIGHT (mm)	APPROX NETT. WEIGHT (kg)
4GS-2/06	291	2.75
4GS-2/09	357	3.25
4GS-2/13	445	4.45
4GS-2/15	489	5.05
4GS-2/18	554	5.65
4GS-2/23	665	7.05
4GS-2/28	775	8.15
4GS-2/33	1022	12.00
4GS-2/40	1214	14.25
4GS-2/48	1382	16.85
4GS-2/55	1550	19.70
4GS-2/65	1838	22.10
4GS-2/75	2078	25.80
4GS-2/90	2438	30.50

PUMP MODEL	HEIGHT (mm)	APPROX NETT. WEIGHT (kg)
4GS-3/06	291	2.90
4GS-3/09	357	3.40
4GS-3/12	423	4.25
4GS-3/15	489	5.30
4GS-3/18	555	6.05
4GS-3/22	643	6.95
4GS-3/25	709	7.75
4GS-3/29	797	8.40
4GS-3/33	1022	12.10
4GS-3/39	1166	14.10
4GS-3/45	1334	16.25
4GS-3/52	1502	18.10
4GS-3/60	1718	20.90
4GS-3/75	2078	26.75



# 4" GS SERIES PUMPS

## HEIGHT & WEIGHT TABLE

HEIGHT & WEIGHT

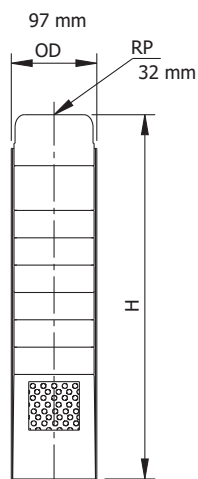

PUMP MODEL	HEIGHT (mm)	APPROX NETT. WEIGHT (kg)
4GS-5/04	255	2.4
4GS-5/06	303	2.98
4GS-5/08	351	3.58
4GS-5/12	447	4.55
4GS-5/21	567	5.86
4GS-5/17	663	6.75
4GG-5/25	759	7.95
4GS-5/33	1022	12.10
4GS-5/38	1142	13.35
4GS-5/44	1310	15.95
4GS-5/52	1502	18.35
4GS-5/60	1718	20.75
4GS-5/70	1939	24.96
4GS-5/75	2078	26.75

PUMP MODEL	HEIGHT (mm)	APPROX NETT. WEIGHT (kg)
4GS-8/05	410	4.50
4GS-8/07	482	5.20
4GS-8/09	554	5.90
4GS-8/10	590	6.25
4GS-8/12	662	7.30
4GS-8/15	770	8.50
4GS-8/18	878	9.85
4GS-8/22	1022	11.60
4GS-8/25	1152	12.95
4GS-8/30	1332	14.90
4GS-8/34	1476	17.20
4GS-8/37	1606	18.72
4GS-8/44	1860	22.20
4GS-8/50	2076	25.20
4GS-8/58	2390	30.45
4GS-8/66	2678	34.65
4GS-8/73	2954	38.55

PUMP MODEL	HEIGHT (mm)	APPROX NETT. WEIGHT (kg)
4GS-14/05	573	6.20
4GS-14/07	703	7.62
4GS-14/09	833	9.04
4GS-14/10	898	9.75
4GS-14/11	963	10.47
4GS-14/13	1093	11.89
4GS-14/16	1288	14.02
4GS-14/18	1418	15.52
4GS-14/22	1678	18.90
4GS-14/25	1873	20.80

# 6" GS SERIES PUMPS

Nominal Diameter : 6"

Nominal Flow : 14m<sup>3</sup>/h

Outlet Size : 2"/2½"\*\*\*

## PERFORMANCE CURVES

Flow Range : 6 - 18 m<sup>3</sup>/h

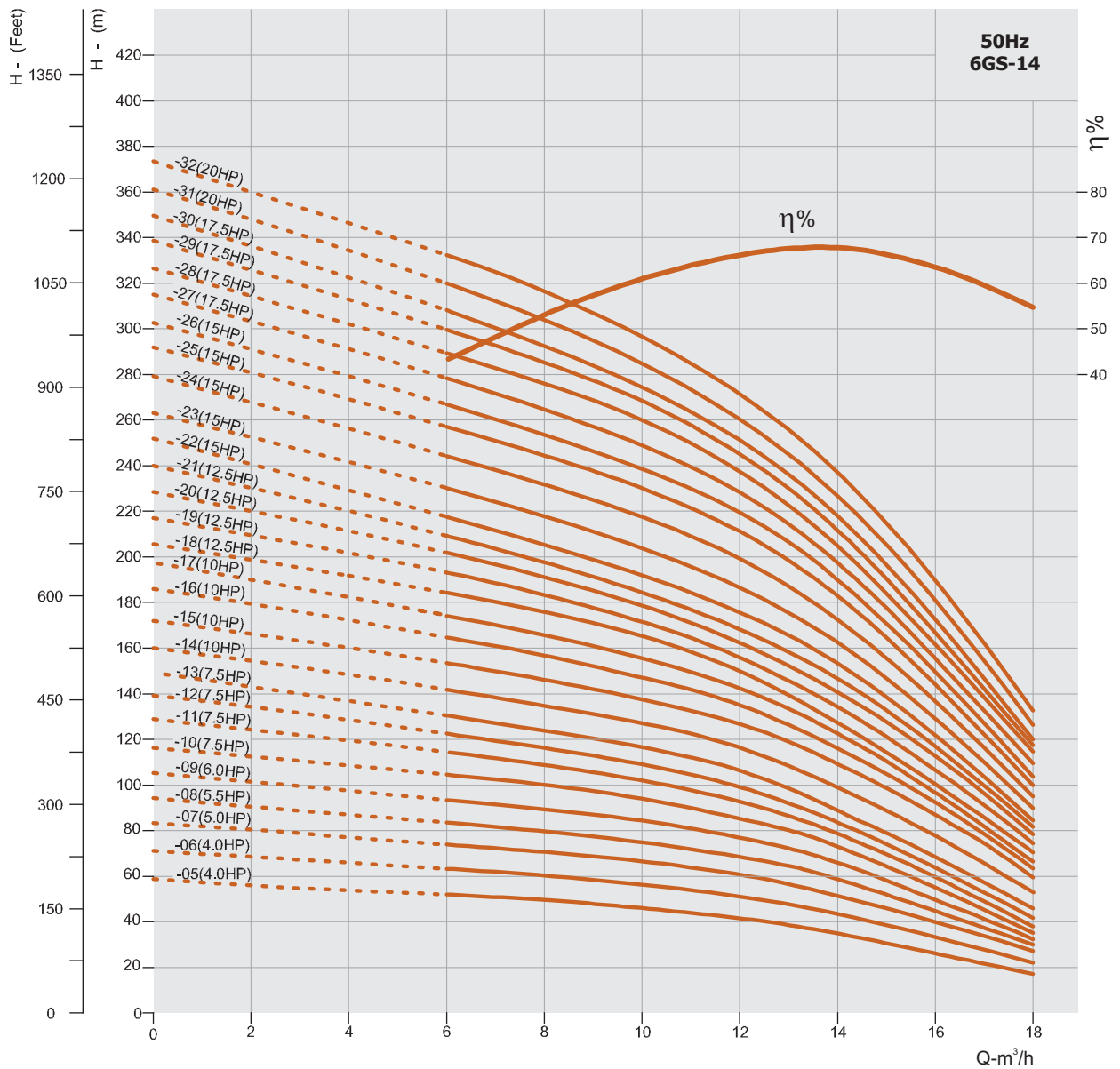

# 6" GS SERIES PUMPS

Nominal Diameter : 6"

Nominal Flow : 14m<sup>3</sup>/h

Outlet Size : 2"/2 1/2"\*\*\*

## PERFORMANCE CURVES

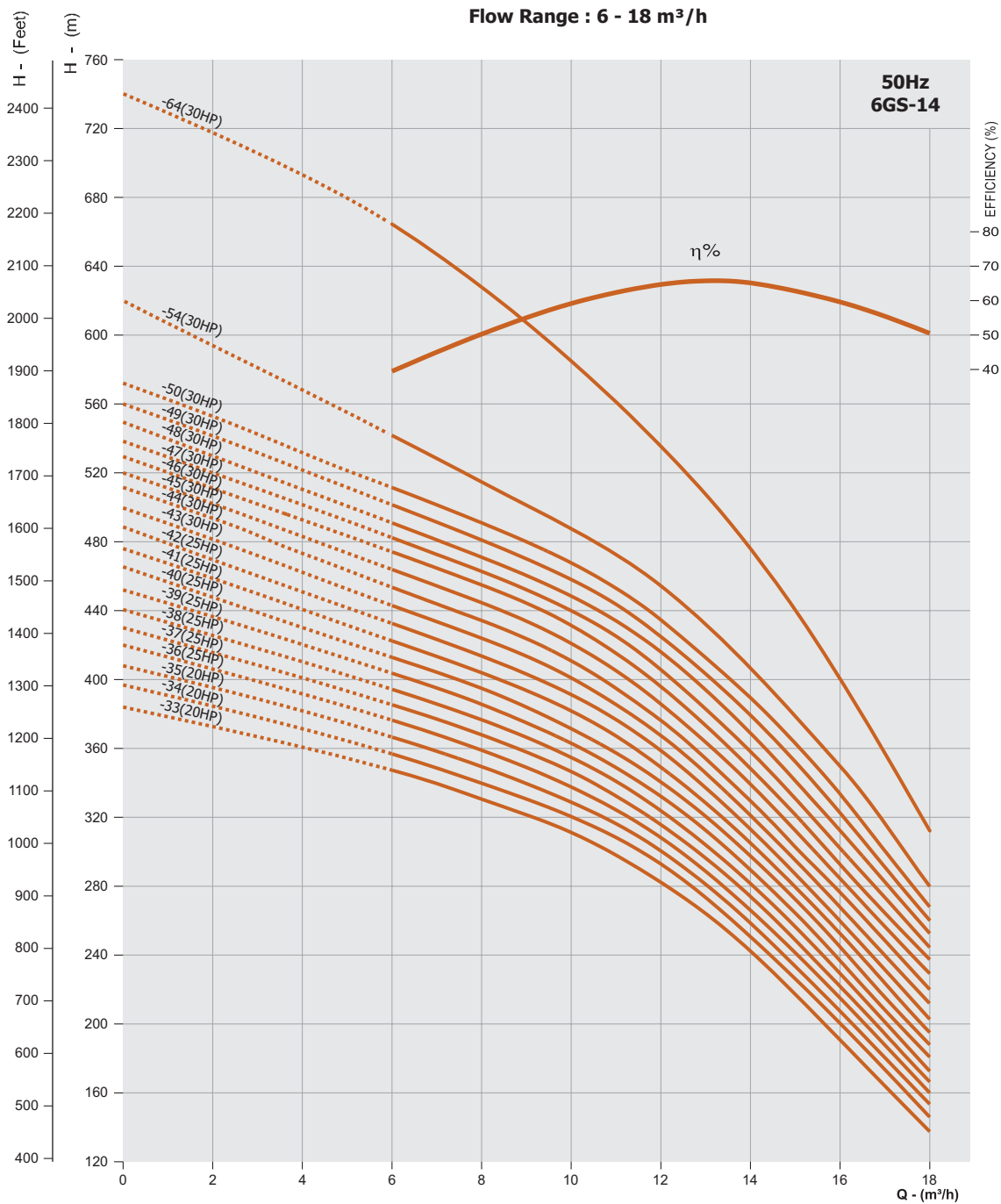

# 6" GS SERIES PUMPS

Nominal Diameter : 6"

Nominal Flow : 17m<sup>3</sup>/h

Outlet Size : 2½"/3"\*\*\*

## PERFORMANCE CURVES

Flow Range : 4 - 22 m<sup>3</sup>/h

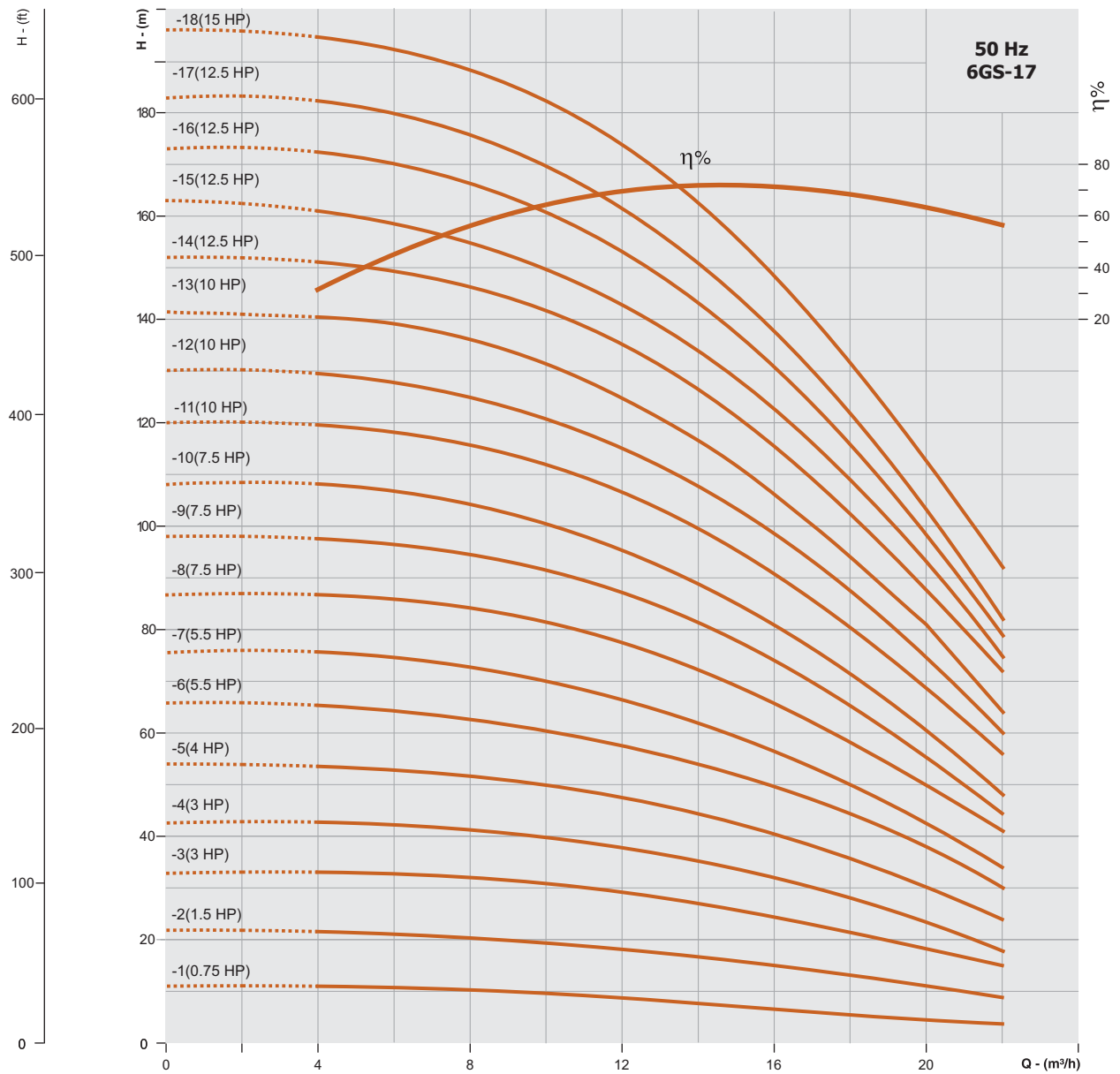

# 6" GS SERIES PUMPS

Nominal Diameter : 6"    Nominal Flow : 17m<sup>3</sup>/h    Outlet Size : 2½"/3"\*\*\*

## PERFORMANCE CURVES

Flow Range : 4 - 22 m<sup>3</sup>/h

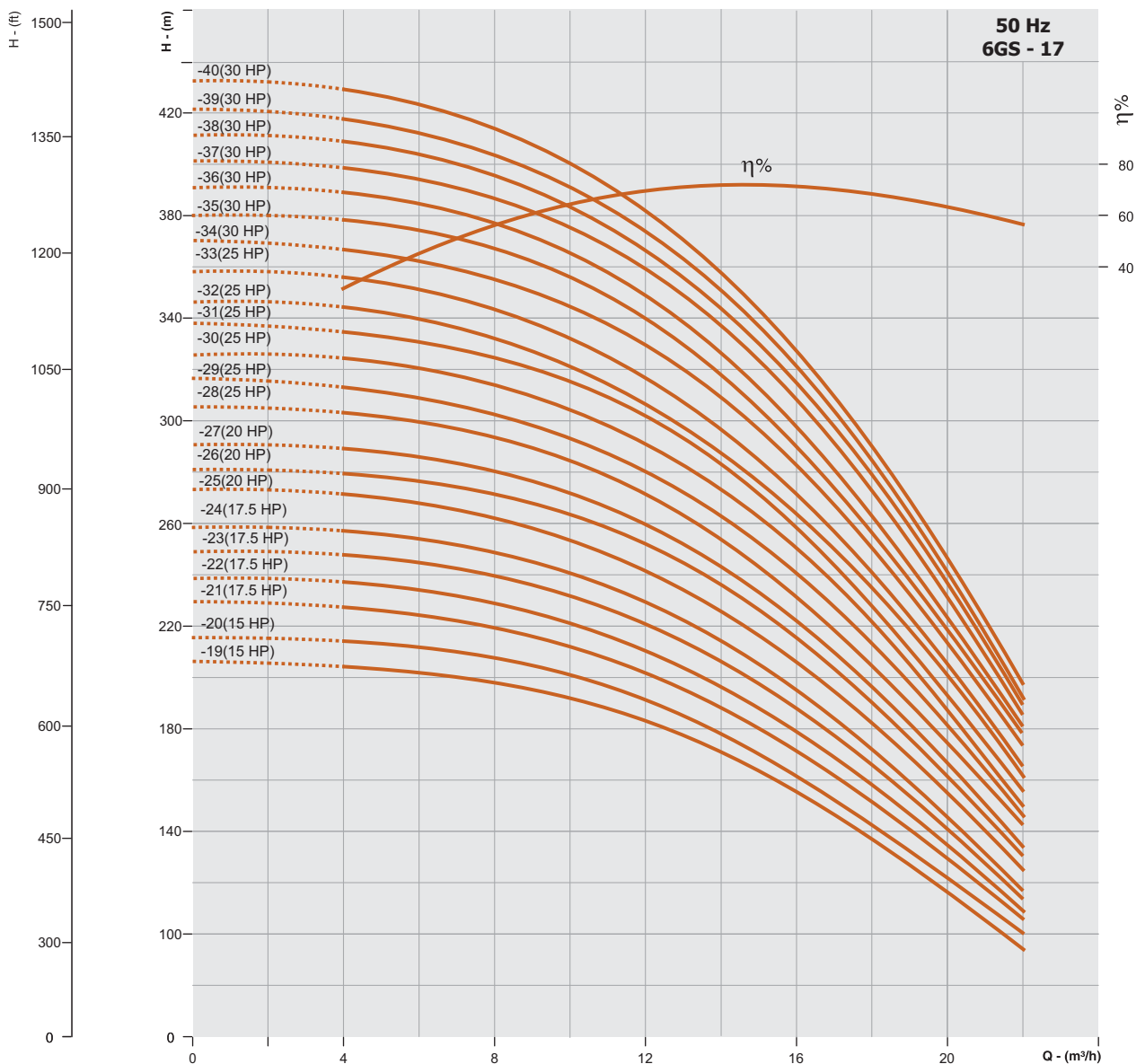

# 6" GS SERIES PUMPS

Nominal Diameter : 6"

Nominal Flow : 17m<sup>3</sup>/h

Outlet Size : 2½"/3"\*\*\*

## PERFORMANCE CURVES

Flow Range : 4 - 22 m<sup>3</sup>/h

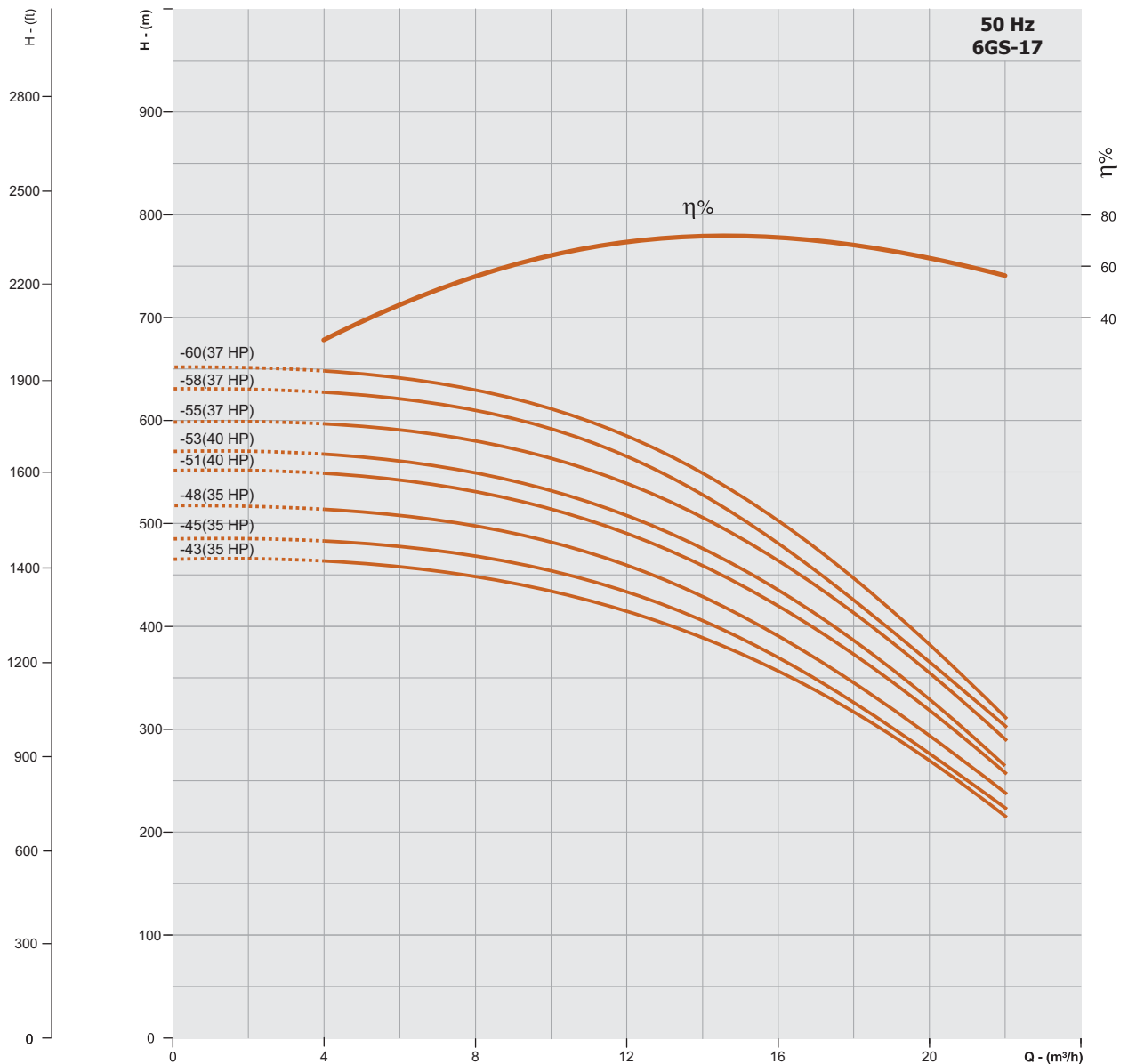

# 6" GS SERIES PUMPS

Nominal Diameter : 6" Nominal Flow : 18m<sup>3</sup>/h Outlet Size : 2½"

## PERFORMANCE CURVES

Flow Range : 7 - 24 m<sup>3</sup>/h

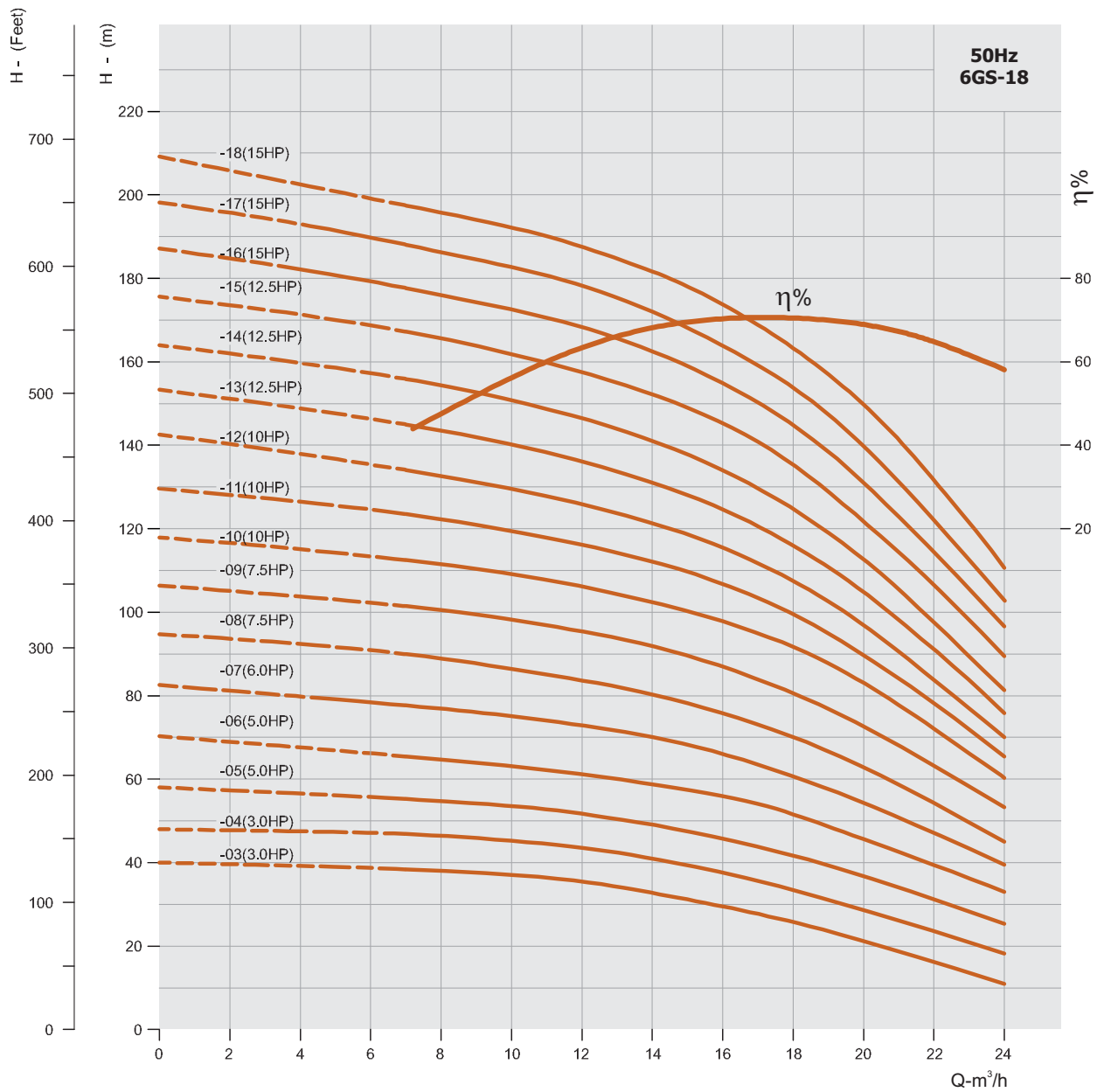

# 6" GS SERIES PUMPS

Nominal Diameter : 6"    Nominal Flow : 18m<sup>3</sup>/h    Outlet Size : 2½"

## PERFORMANCE CURVES

Flow Range : 7 - 24 m<sup>3</sup>/h

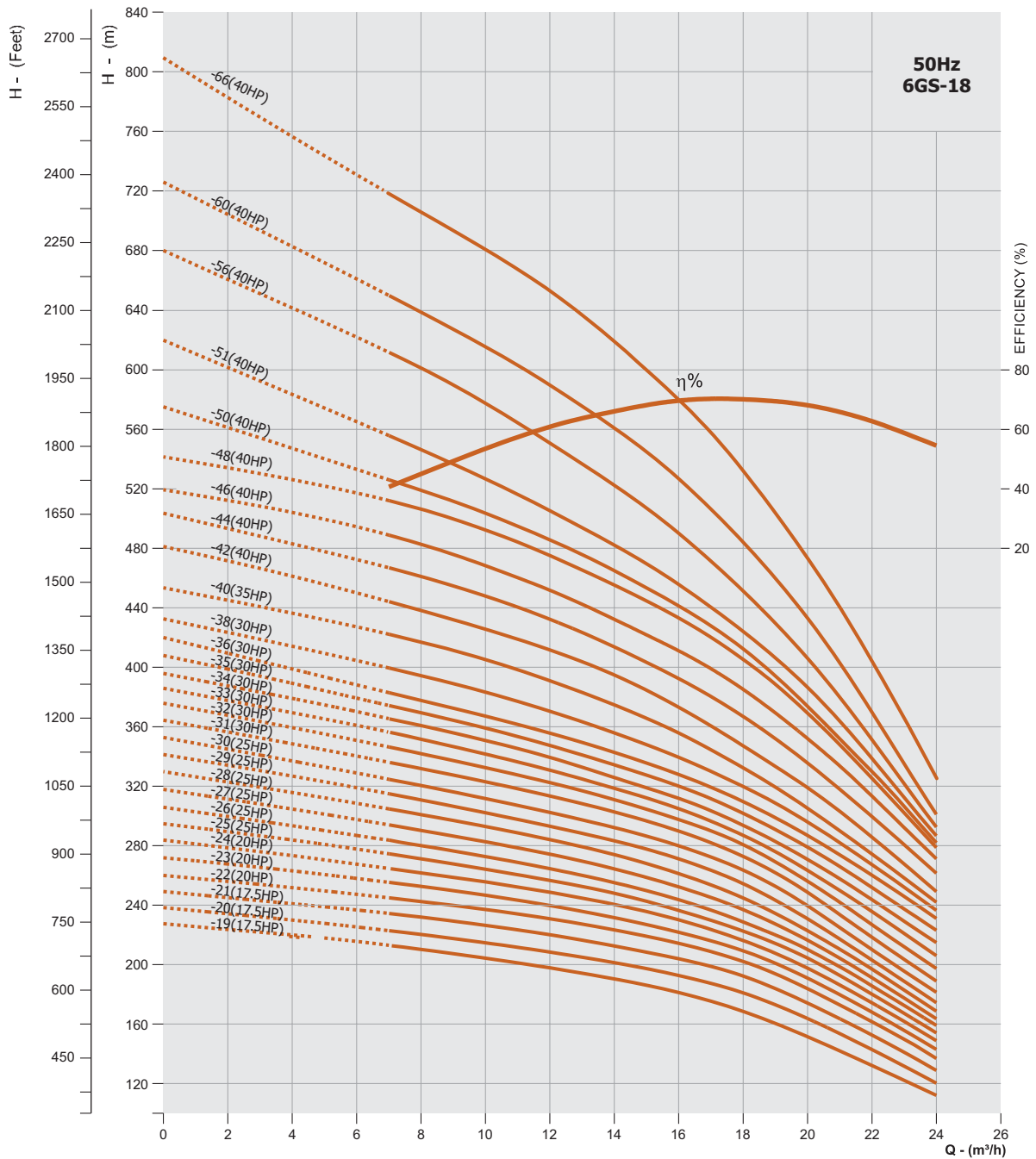



# 6" GS SERIES PUMPS

Nominal Diameter : 6"    Nominal Flow : 22m<sup>3</sup>/h    Outlet Size : 2½" / 3"

## PERFORMANCE CURVES

Flow Range : 9 - 29 m<sup>3</sup>/h

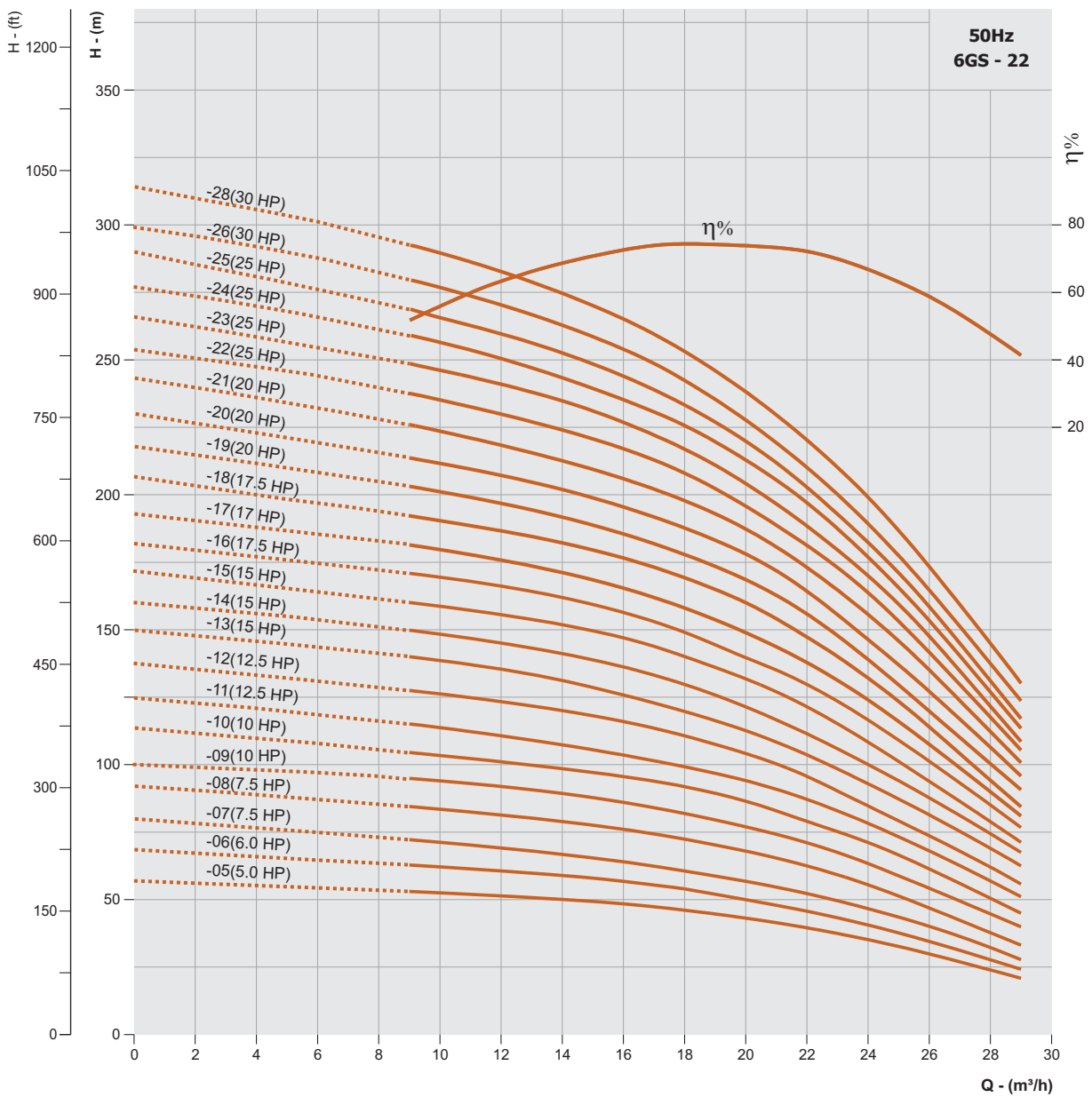

# 6" GS SERIES PUMPS

Nominal Diameter : 6"    Nominal Flow : 22m<sup>3</sup>/h    Outlet Size : 2½" / 3"

## PERFORMANCE CURVES

Flow Range : 9 - 29 m<sup>3</sup>/h

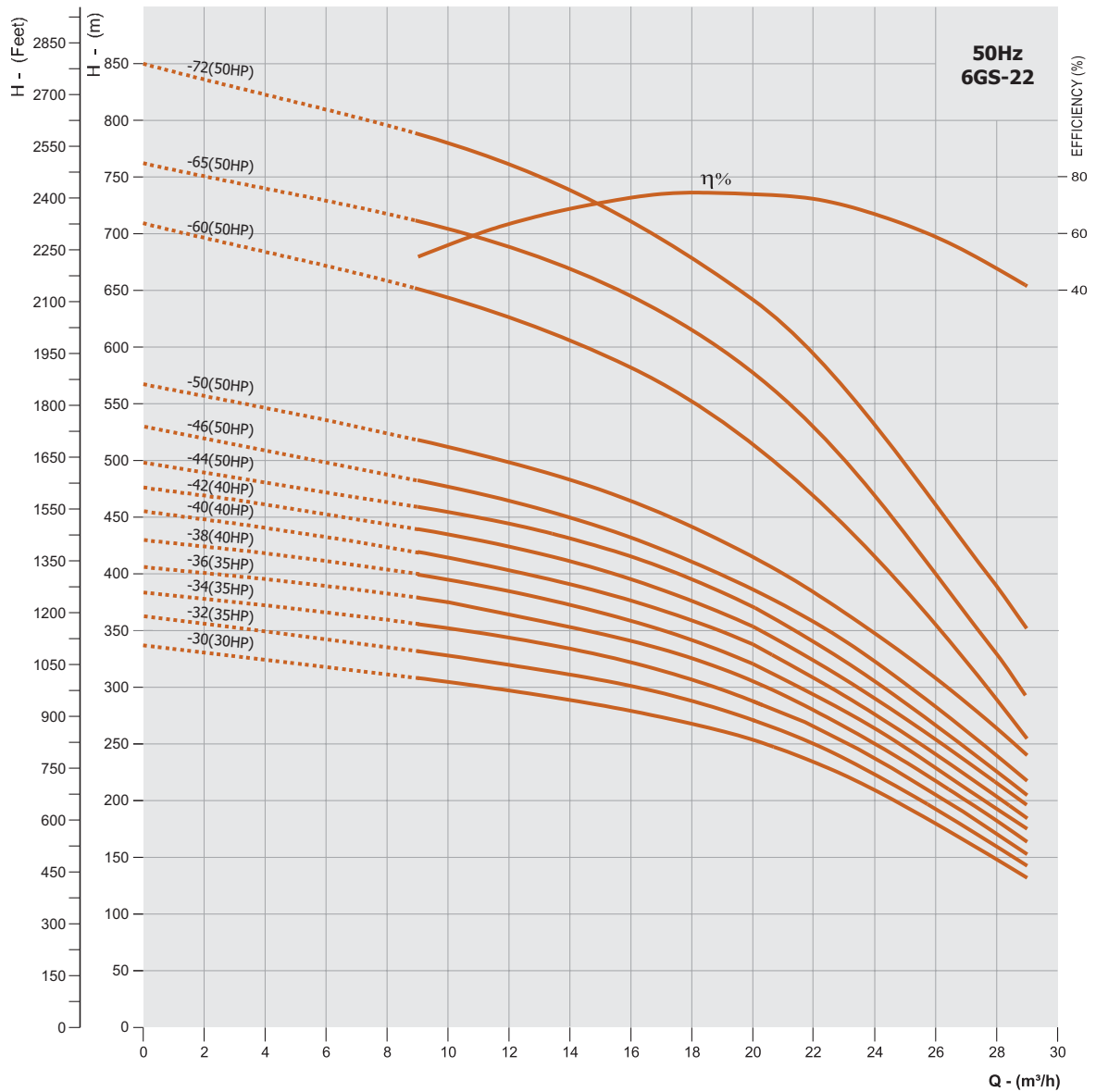

# 6" GS SERIES PUMPS

Nominal Diameter : 6" Nominal Flow : 30m<sup>3</sup>/h Outlet Size : 3"

## PERFORMANCE CURVES

Flow Range : 6 - 36 m<sup>3</sup>/h

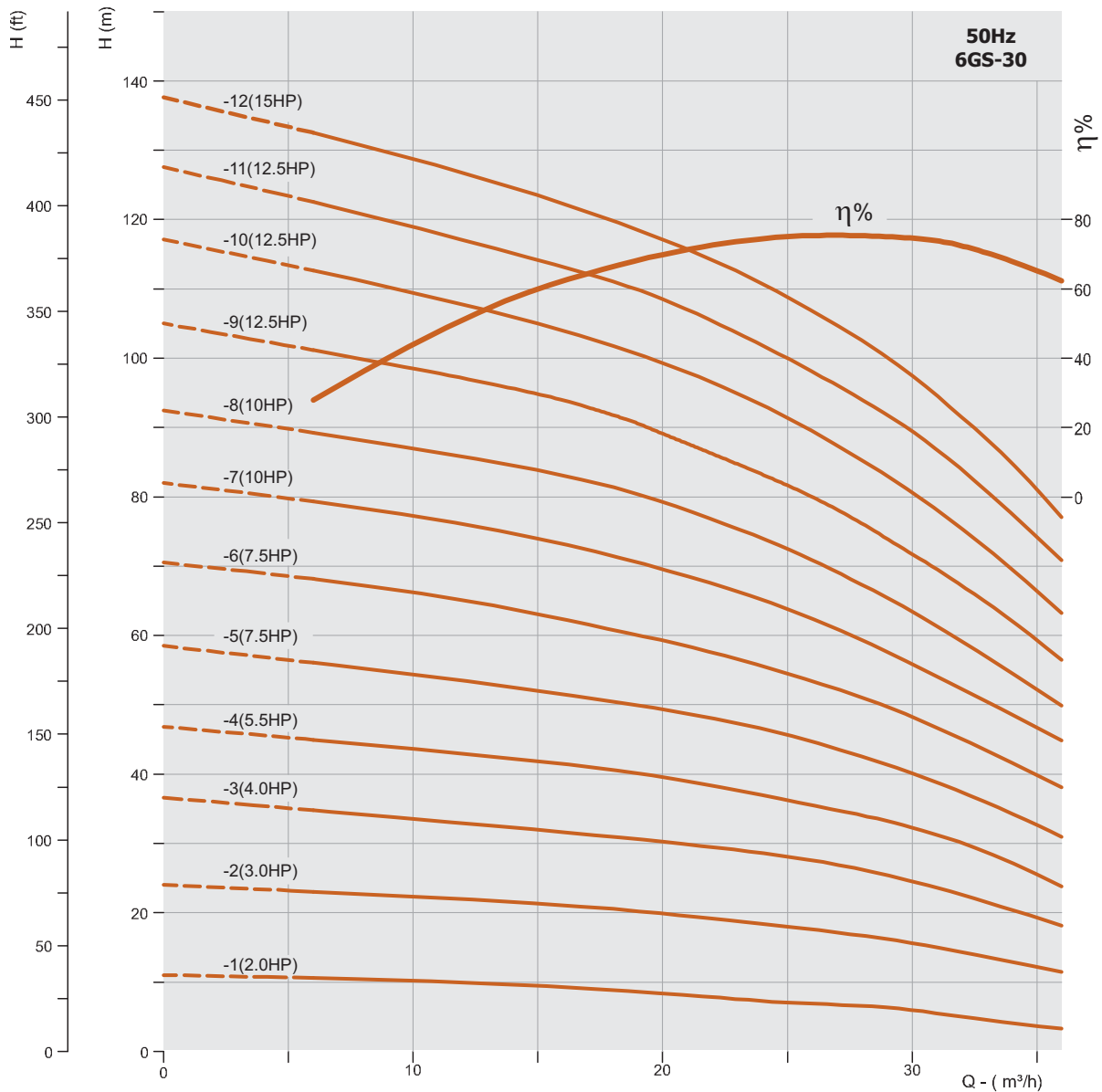

# 6" GS SERIES PUMPS

Nominal Diameter : 6" Nominal Flow : 30m<sup>3</sup>/h Outlet Size : 3"

## PERFORMANCE CURVES

Flow Range : 6 - 36 m<sup>3</sup>/h

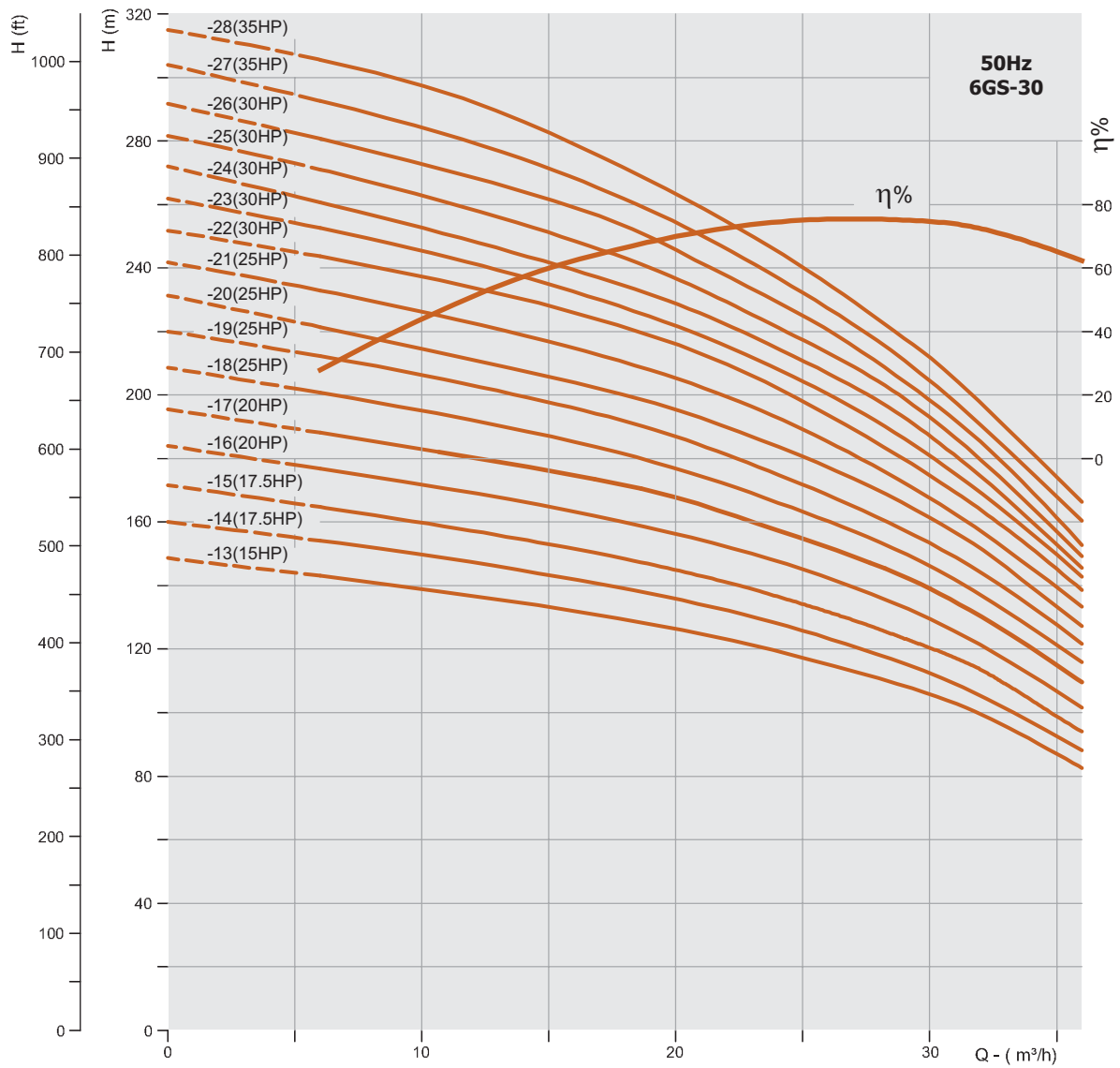

# 6" GS SERIES PUMPS

Nominal Diameter : 6" Nominal Flow : 30m<sup>3</sup>/h Outlet Size : 3"

## PERFORMANCE CURVES

Flow Range : 6 - 36 m<sup>3</sup>/h

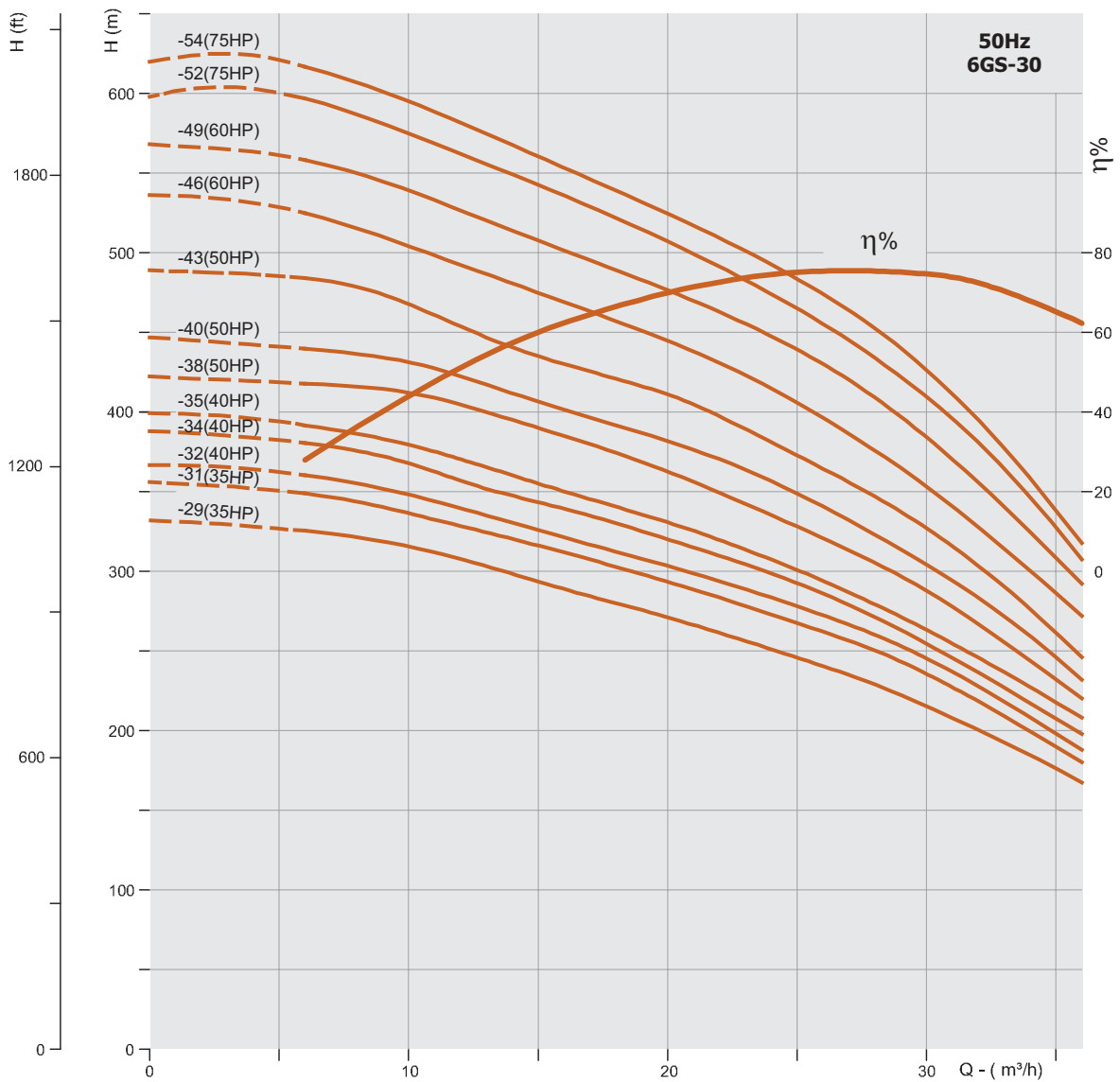

# 6" GS SERIES PUMPS

Nominal Diameter : 6"

Nominal Flow : 48 m<sup>3</sup>/h

Outlet Size : 3"

## PERFORMANCE CURVES

Flow Range : 29 - 60 m<sup>3</sup>/h

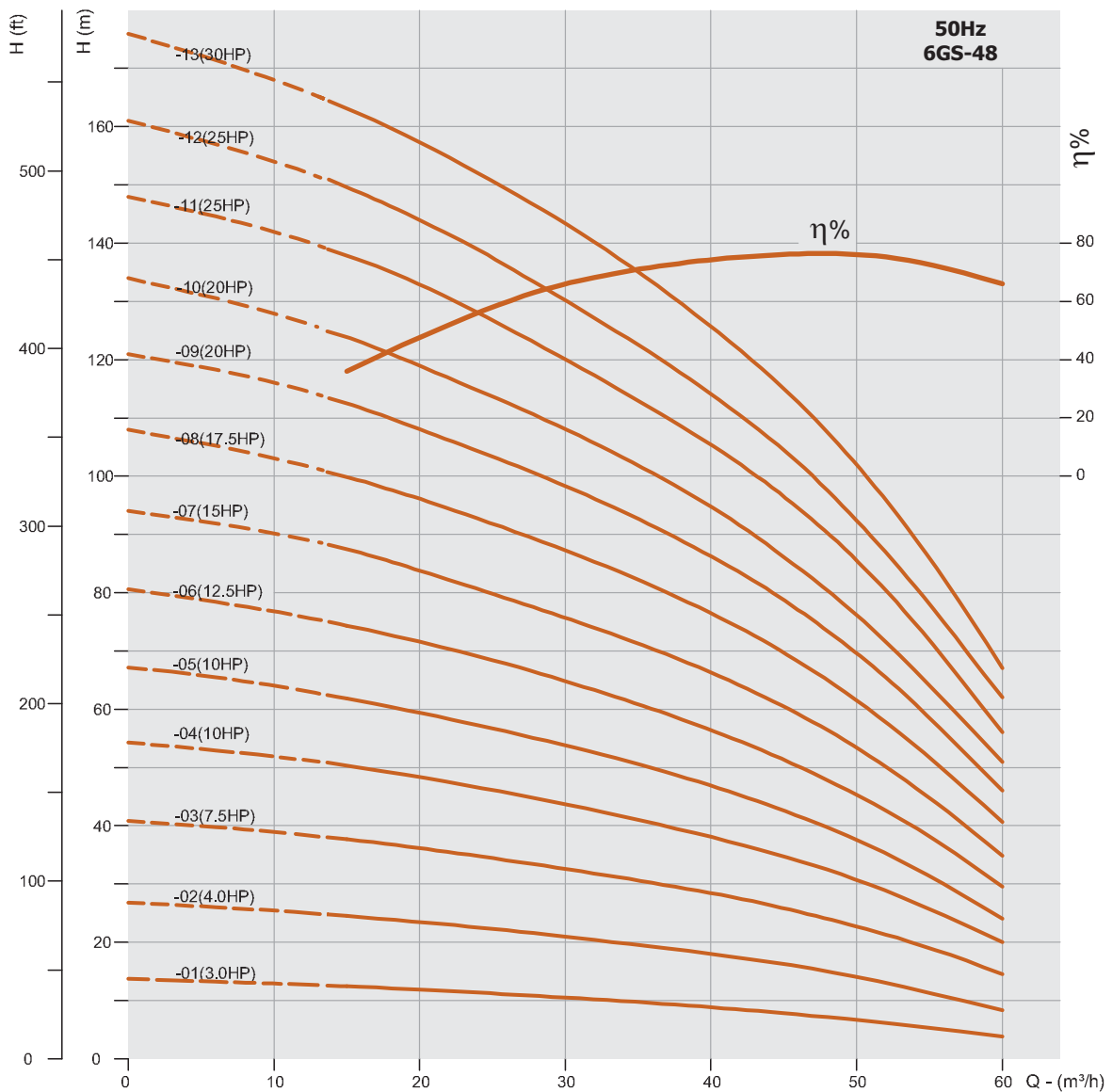

# 6" GS SERIES PUMPS

Nominal Diameter : 6"

Nominal Flow : 48m<sup>3</sup>/h

Outlet Size : 3"

## PERFORMANCE CURVES

Flow Range : 29 - 60 m<sup>3</sup>/h

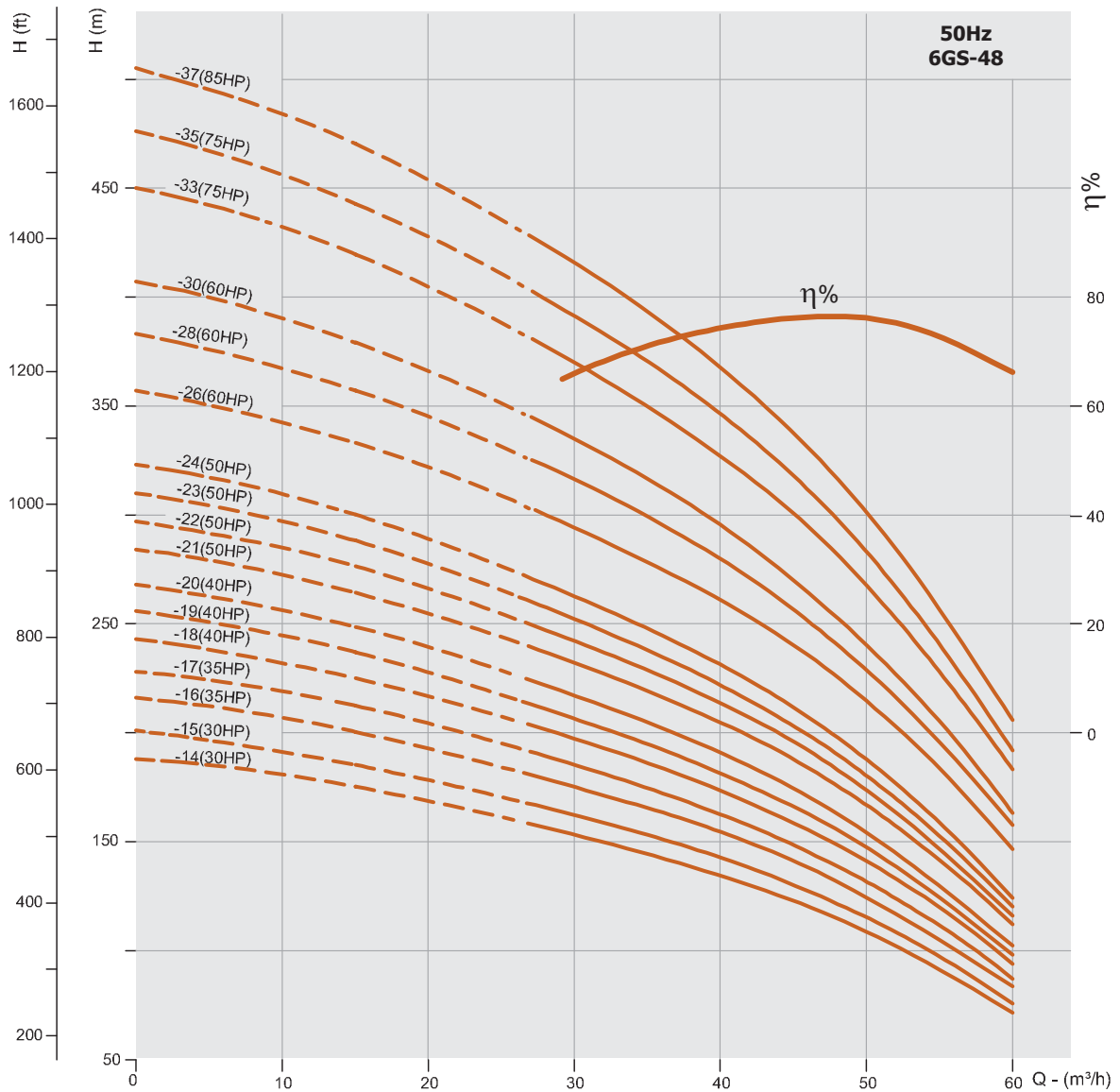

# 6" GS SERIES PUMPS

Nominal Diameter : 6"    Nominal Flow : 60 m<sup>3</sup>/h    Outlet Size : 3"/4"

## PERFORMANCE CURVES

Flow Range : 28 - 80 m<sup>3</sup>/h

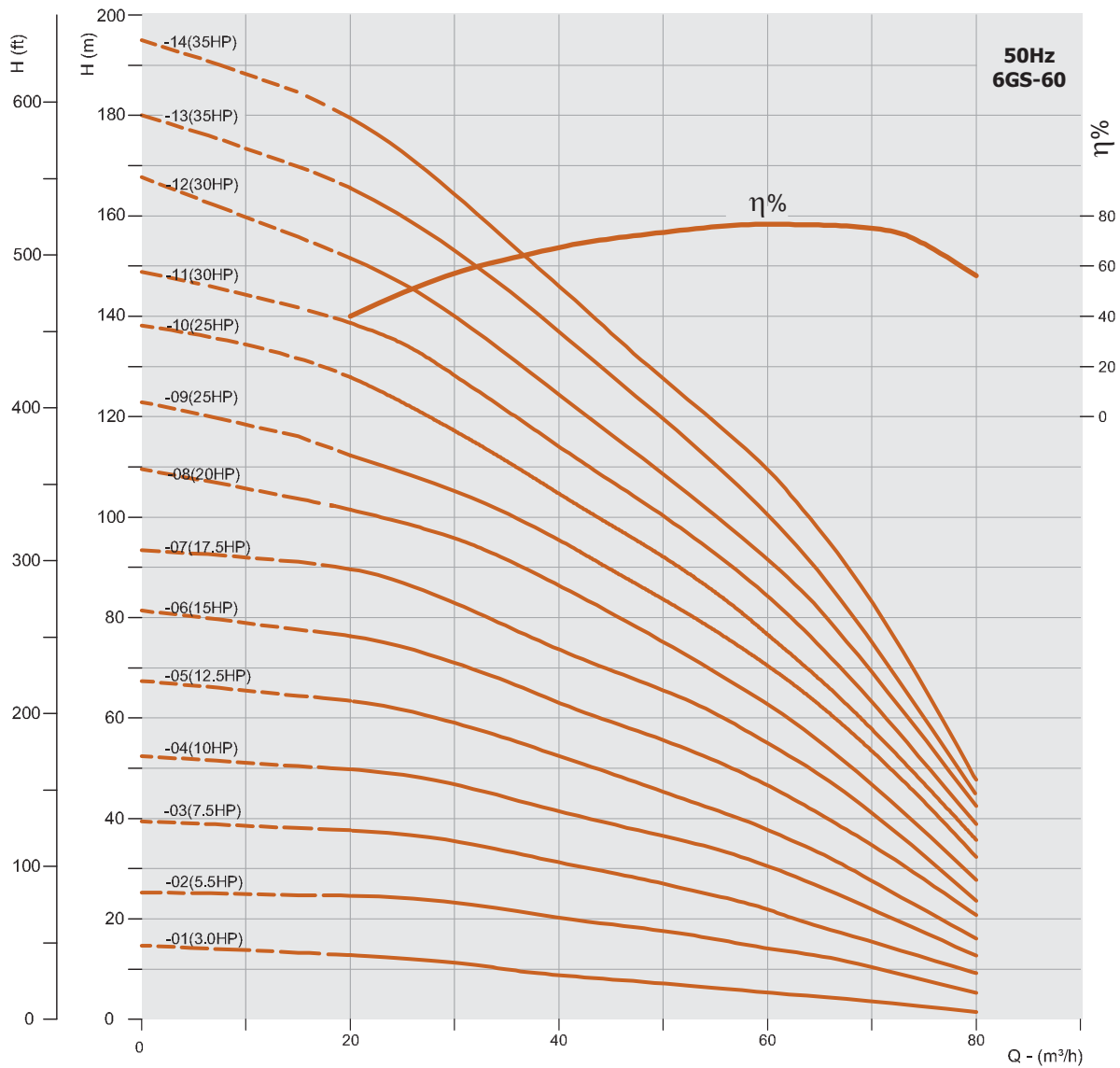



# 6" GS SERIES PUMPS

Nominal Diameter : 6"    Nominal Flow : 60 m<sup>3</sup>/h    Outlet Size : 3"/4"

## PERFORMANCE CURVES

Flow Range : 28 - 80 m<sup>3</sup>/h

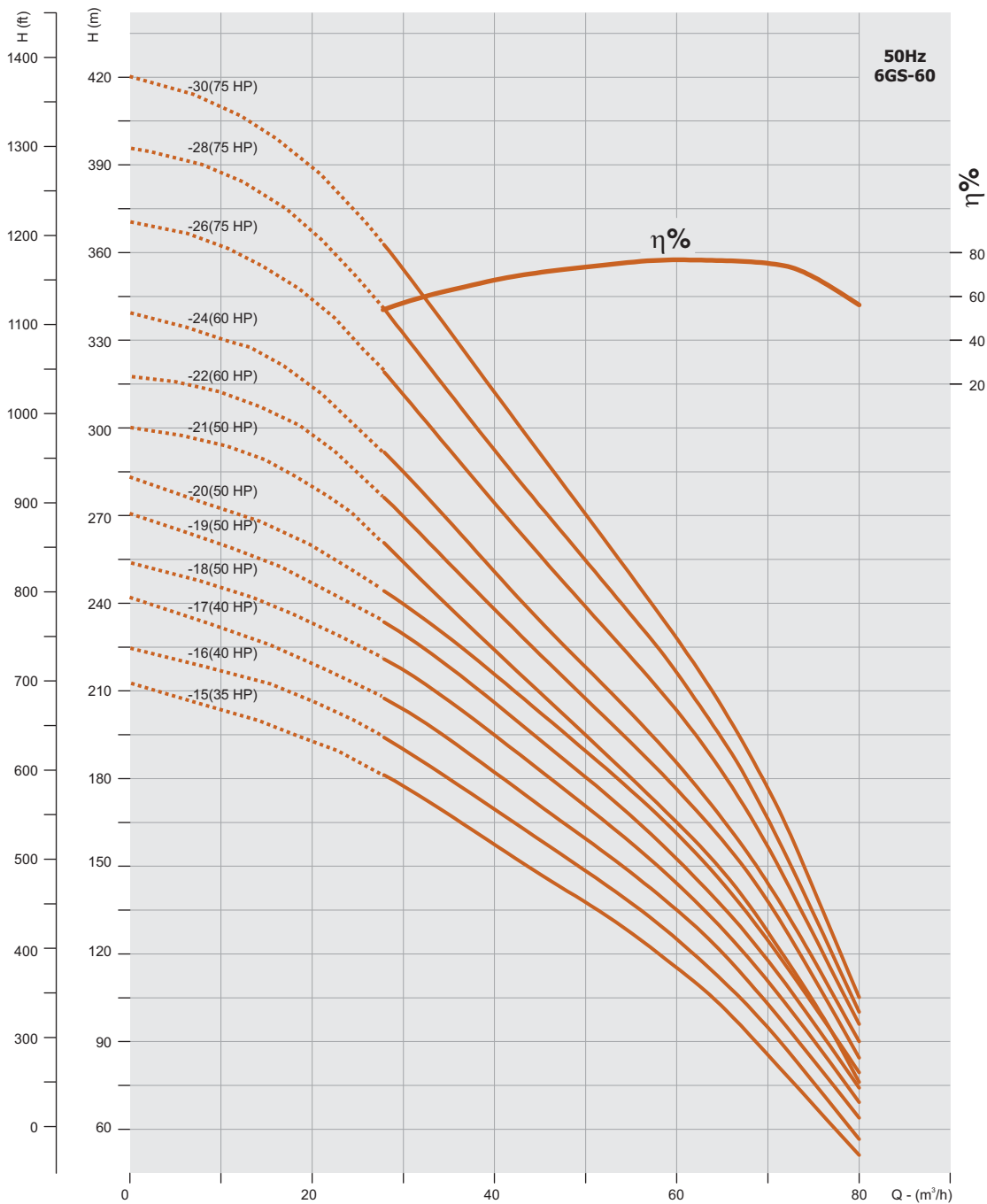

# 6" GS SERIES PUMPS

Nominal Diameter : 6"

## HEIGHT & WEIGHT TABLE

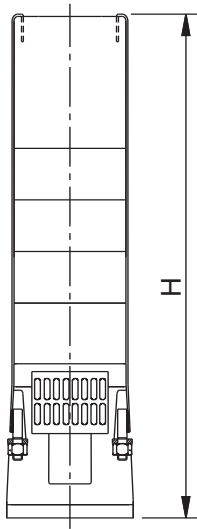

PUMP MODEL	HEIGHT (mm)	APPROX NETT. WEIGHT (kg)
6GS-14/05	491	11.56
6GS-14/06	530	12.47
6GS-14/07	569	13.37
6GS-14/08	608	14.28
6GS-14/09	647	15.18
6GS-14/10	686	16.29
6GS-14/11	725	17.21
6GS-14/12	764	18.12
6GS-14/13	803	19.04
6GS-14/14	842	19.95
6GS-14/15	881	20.87
6GS-14/16	920	21.79
6GS-14/17	959	22.70
6GS-14/18	998	23.62
6GS-14/19	1037	24.53
6GS-14/20	1076	25.45
6GS-14/21	1115	26.37
6GS-14/22	1154	27.28
6GS-14/23	1193	28.20
6GS-14/24	1232	29.11
6GS-14/25	1271	30.03
6GS-14/26	1310	30.94
6GS-14/27	1349	31.86
6GS-14/28	1388	32.78
6GS-14/29	1427	33.69
6GS-14/30	1466	34.61
6GS-14/31	1505	35.52
6GS-14/32	1544	36.44
6GS-14/33	1583	37.36
6GS-14/34	1622	38.27
6GS-14/35	1661	39.19
6GS-14/36	1700	40.10
6GS-14/37	1739	41.02
6GS-14/38	1778	41.93
6GS-14/39	1817	42.85
6GS-14/40	1856	43.77
6GS-14/41	1895	44.68
6GS-14/42	1934	45.60
6GS-14/43	1973	46.51
6GS-14/44	2012	47.43
6GS-14/45	2051	48.35
6GS-14/46	2090	49.26
6GS-14/47	2129	50.18
6GS-14/48	2168	51.09
6GS-14/49	2207	52.01
6GS-14/50	2246	52.92
6GS-14/54	2402	57.2
6GS-14/64	2792	69.2

## 6" GS SERIES PUMPS

Nominal Diameter : 6"

### HEIGHT & WEIGHT TABLE

PUMP MODEL	HEIGHT (mm)	APPROX NETT. WEIGHT (kg)
6GS-17/1	324	5.5
6GS-17/2	384	7.3
6GS-17/3	444	7.1
6GS-17/4	504	9.1
6GS-17/5	564	10
6GS-17/6	624	11
6GS-17/7	684	13
6GS-17/8	1421	14/13.5
6GS-17/9	1481	16/14.5
6GS-17/10	1541	17/16.5
6GS-17/11	1701	19/19
6GS-17/12	1761	20/21
6GS-17/13	1821	22/21
6GS-17/14	1721	23.5
6GS-17/15	1781	24.5
6GS-17/16	1847	25.5
6GS-17/17	1907	26.5
6GS-17/18	1997	27.5
6GS-17/19	2057	29.5
6GS-17/20	2117	31.5
6GS-17/21	2207	33.5
6GS-17/22	2267	34.5
6GS-17/23	2327	35.5
6GS-17/24	2387	37.5
6GS-17/25	2482	38.5
6GS-17/26	2542	39.5
6GS-17/27	2602	41.5
6GS-17/28	2717	43
6GS-17/29	2777	44
6GS-17/30	2837	45
6GS-17/31	2897	47
6GS-17/32	2957	48
6GS-17/33	3017	50
6GS-17/34	3137	51
6GS-17/35	3197	52
6GS-17/36	3257	54
6GS-17/37	3317	55
6GS-17/38	3377	56
6GS-17/39	3437	58
6GS-17/40	3497	59

PUMP MODEL	HEIGHT (mm)	APPROX NETT. WEIGHT (kg)
6GS-17/43	4089	94.5
6GS-17/45	4209	97.5
6GS-17/48	4389	103.5
6GS-17/51	4639	108.5
6GS-17/53	4759	111.5
6GS-17/55	5247	114
6GS-17/58	5427	120
6GS-17/60	5547	123

# 6" GS SERIES PUMPS

Nominal Diameter : 6"

## HEIGHT & WEIGHT TABLE

PUMP MODEL	HEIGHT (mm)	APPROX NETT. WEIGHT (kg)
6GS-18/03	427	9.88
6GS-18/04	471	10.84
6GS-18/05	515	11.81
6GS-18/06	559	12.77
6GS-18/07	603	13.74
6GS-18/08	647	14.90
6GS-18/09	691	15.88
6GS-18/10	735	16.86
6GS-18/11	779	17.83
6GS-18/12	823	18.81
6GS-18/13	867	19.79
6GS-18/14	911	20.77
6GS-18/15	955	21.75
6GS-18/16	999	22.73
6GPS-18/17	1043	23.70
6GS-18/18	1087	24.68
6GS-18/19	1131	25.66
6GS-18/20	1175	26.64
6GS-18/21	1219	27.62
6GS-18/22	1263	28.60
6GS-18/23	1307	29.57
6GS-18/24	1351	30.55
6GS-18/25	1395	31.53
6GS-18/26	1439	32.51
6GS-18/27	1483	33.49
6GS-18/28	1527	34.47
6GS-18/29	1571	35.44
6GS-18/30	1615	36.42
6GS-18/31	1659	37.40
6GS-18/32	1703	38.38
6GS-18/33	1747	39.36
6GS-18/34	1791	40.34
6GS-18/35	1835	41.32
6GS-18/36	1879	42.29
6GS-18/38	1967	44.25
6GS-18/40	2055	46.21
6GS-18/42	2143	48.16
6GS-18/44	2231	50.12
6GS-18/46	2319	52.08
6GS-18/48	2407	54.03
6GS-18/50	2570	60.51
6GS-18/51	2539	57.60
6GS-18/56	2803	63.2
6GS-18/60	2979	68.1
6GS-18/66	3243	75.6
6GS-18/72	3507	83.4

PUMP MODEL	HEIGHT (mm)	APPROX NETT. WEIGHT (kg)
6GS-22/05	531	11.80
6GS-22/06	578	12.70
6GS-22/07	625	13.90
6GS-22/08	672	14.87
6GS-22/09	719	15.84
6GS-22/10	766	16.81
6GS-22/11	813	17.79
6GS-22/12	860	18.76
6GS-22/13	907	19.73
6GS-22/14	954	20.70
6GS-22/15	1001	21.67
6GS-22/16	1048	22.65
6GS-22/17	1095	23.62
6GS-22/18	1142	24.59
6GS-22/19	1189	25.56
6GS-22/20	1236	26.53
6GS-22/21	1283	27.51
6GS-22/22	1330	28.48
6GS-22/23	1377	29.45
6GS-22/24	1424	30.42
6GS-22/25	1471	31.39
6GS-22/26	1518	32.37
6GS-22/28	1612	34.31
6GS-22/30	1706	36.25
6GS-22/32	1800	38.20
6GS-22/34	1894	40.14
6GS-22/36	1988	42.08
6GS-22/38	2082	44.03
6GS-22/40	2176	45.97
6GS-22/42	2270	47.92
6GS-22/44	2364	49.86
6GS-22/46	2458	51.80
6GS-22/50	2646	55.69
6GS-22/60	3136	66.7
6GS-22/65	3381	72.3
6GS-22/72	3760	78.6

## 6" GS SERIES PUMPS

Nominal Diameter : 6"

### HEIGHT & WEIGHT TABLE

PUMP MODEL	HEIGHT (mm)	APPROX NETT. WEIGHT (kg)
6GS-30/01	386	8.10
6GS-30/02	482	9.98
6GS-30/03	578	11.85
6GS-30/04	674	13.73
6GS-30/05	770	15.61
6GS-30/06	866	17.49
6GS-30/07	962	19.36
6GS-30/08	1058	21.24
6GS-30/09	1154	23.12
6GS-30/10	1250	25.00
6GS-30/11	1346	26.88
6GS-30/12	1442	28.76
6GS-30/13	1538	30.44
6GS-30/14	1634	32.51
6GS-30/15	1730	34.39
6GS-30/16	1826	36.27
6GS-30/17	1922	38.15
6GS-30/18	2018	40.03
6GS-30/19	2114	41.91
6GS-30/20	2210	43.78
6GS-30/21	2306	45.66
6GS-30/22	2402	47.54
6GS-30/23	2498	49.42
6GS-30/24	2594	51.30
6GS-30/25	2690	53.18
6GS-30/26	2786	55.24
6GS-30/27	2882	57.12
6GS-30/28	2978	59.00
6GS-30/29	3074	60.88
6GS-30/31	3266	64.63
6GS-30/32	3362	66.51
6GS-30/34	3554	70.27
6GS-30/35	3650	72.15
6GS-30/38	3938	77.78
6GS-30/40	4130	81.54
6GS-30/43	4418	87.17
6GS-30/46	4706	92.81
6GS-30/49	4994	98.45
6GS-30/52	5282	106.1
6GS-30/54	5474	111.74

## 6" GS SERIES PUMPS

Nominal Diameter : 6"

### HEIGHT & WEIGHT TABLE

PUMP MODEL	HEIGHT (mm)	APPROX NETT. WEIGHT (kg)
6GS-48/01	403	8.69
6GS-48/02	516	10.98
6GS-48/03	629	13.26
6GS-48/04	742	15.55
6GS-48/05	855	17.90
6GS-48/06	968	20.19
6GS-48/07	1081	22.47
6GS-48/08	1194	24.76
6GS-48/09	1307	27.05
6GS-48/10	1420	29.33
6GS-48/11	1533	31.62
6GS-48/12	1646	33.91
6GS-48/13	1759	36.19
6GS-48/14	1872	38.48
6GS-48/15	1985	40.77
6GS-48/16	2098	43.05
6GS-48/17	2211	45.34
6GS-48/18	2324	47.63
6GS-48/19	2437	49.91
6GS-48/20	2550	52.20
6GS-48/21	2663	54.49
6GS-48/22	2776	56.77
6GS-48/23	2889	59.06
6GS-48/24	3002	61.34
6GS-48/26	3228	65.92
6GS-48/28	3454	70.49
6GS-48/30	3680	75.06
6GS-48/33	4019	83.94
6GS-48/35	4245	88.51
6GS-48/37	4471	93.08

PUMP MODEL	HEIGHT (mm)	APPROX NETT. WEIGHT (kg)
6GS-60/01	403	7.40
6GS-60/02	516	11.10
6GS-60/03	629	13.44
6GS-60/04	742	15.79
6GS-60/05	855	18.20
6GS-60/06	968	20.55
6GS-60/07	1081	22.89
6GS-60/08	1194	25.24
6GS-60/09	1307	27.59
6GS-60/10	1420	29.93
6GS-60/11	1533	32.28
6GS-60/12	1646	34.63
6GS-60/13	1759	36.97
6GS-60/14	1872	39.32
6GS-60/15	1985	41.67
6GS-60/16	2098	44.01
6GS-60/17	2211	46.36
6GS-60/18	2324	48.71
6GS-60/19	2437	51.05
6GS-60/20	2550	53.40
6GS-60/21	2663	55.75
6GS-60/22	2776	58.10
6GS-60/24	3002	62.79
6GS-60/26	3228	69.50
6GS-60/28	3454	74.20
6GS-60/30	3680	78.90

# 8" GS SERIES PUMPS

Nominal Diameter : 8"    Nominal Flow : 78 m<sup>3</sup>/h    Outlet Size : 4"/5"

## PERFORMANCE CURVES

Flow Range : 30 - 100 m<sup>3</sup>/h

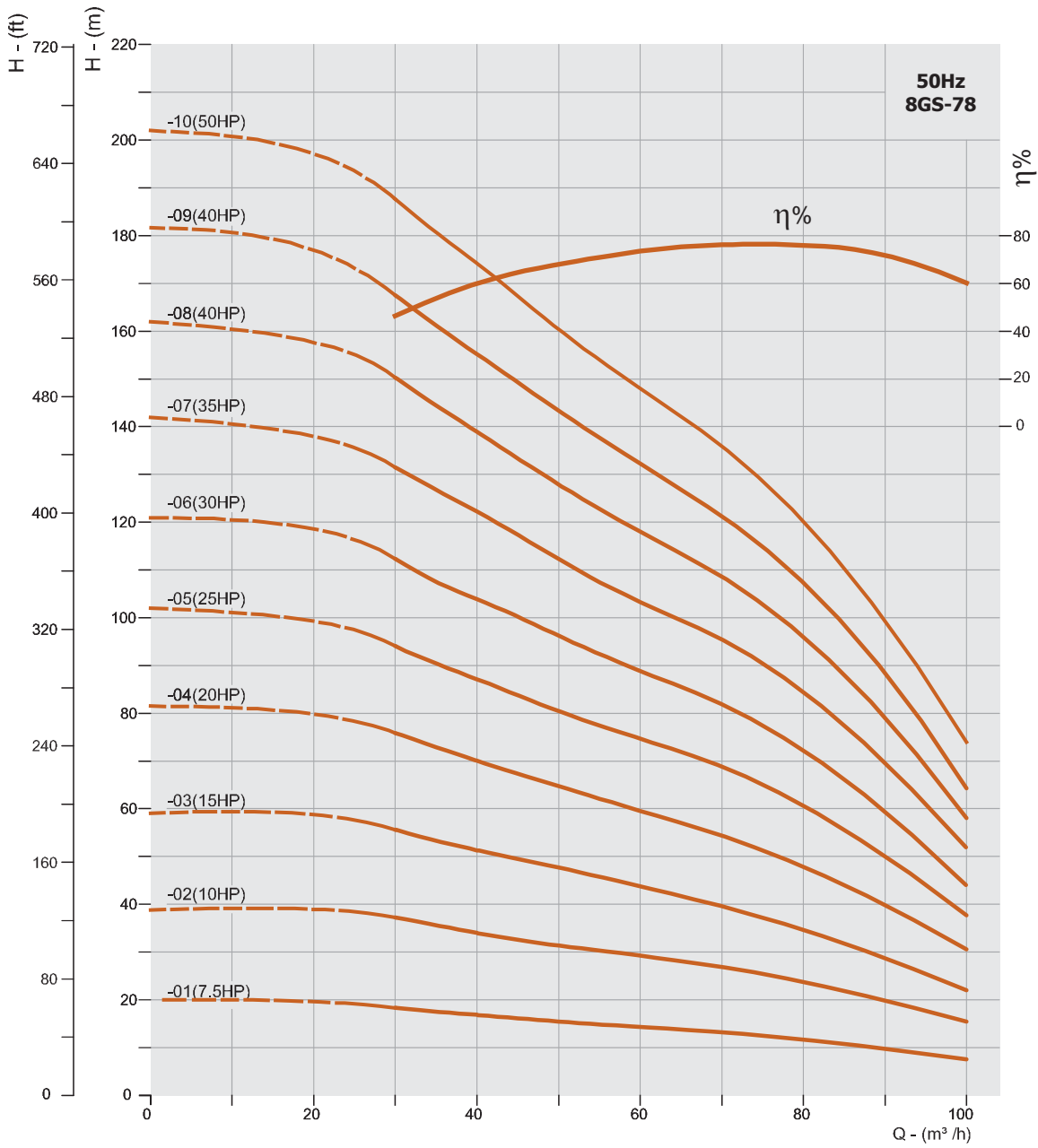

# 8" GS SERIES PUMPS

Nominal Diameter : 8"    Nominal Flow : 78 m<sup>3</sup>/h    Outlet Size : 4"/5"

## PERFORMANCE CURVES

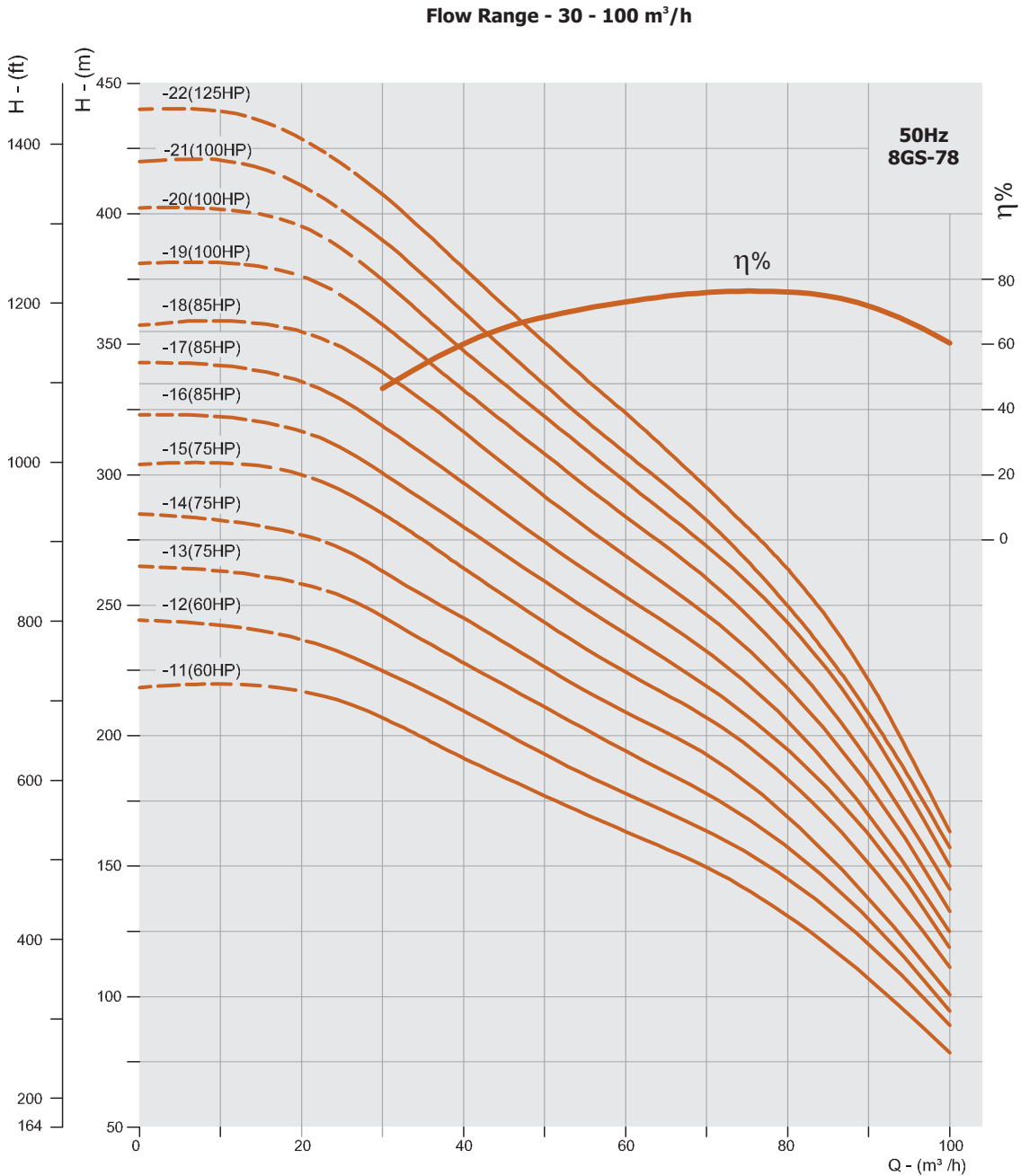



# 8" GS SERIES PUMPS

Nominal Diameter : 8" Nominal Flow : 95 m<sup>3</sup>/h Outlet Size : 5"

## PERFORMANCE CURVES

Flow Range : 40 - 126 m<sup>3</sup>/h

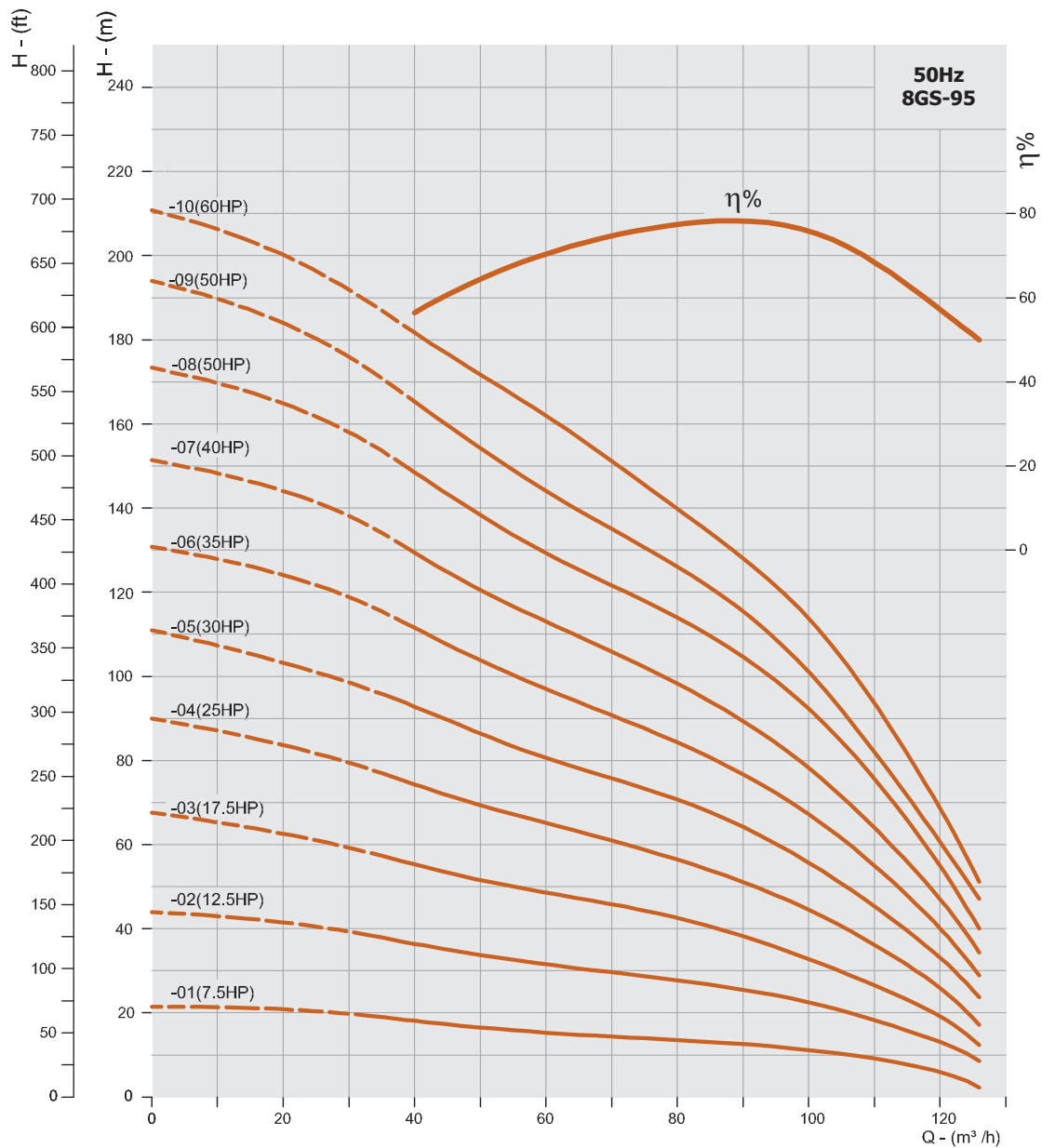

# 8" GS SERIES PUMPS

Nominal Diameter : 8" Nominal Flow : 95 m<sup>3</sup>/h Outlet Size : 5"

## PERFORMANCE CURVES

Flow Range : 40 - 126 m<sup>3</sup>/h

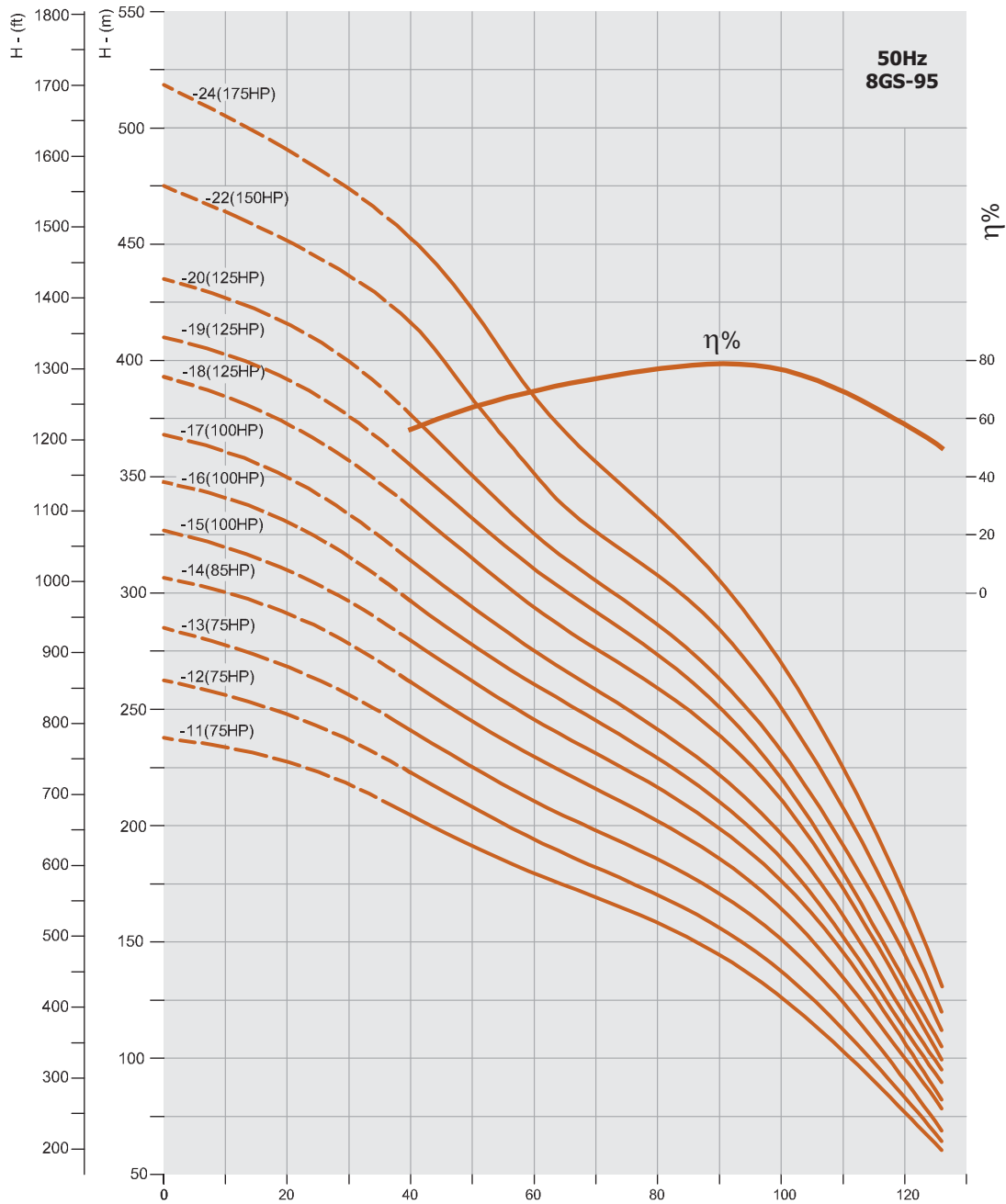

## 8" GS SERIES PUMPS

Nominal Diameter : 8"

### HEIGHT & WEIGHT TABLE

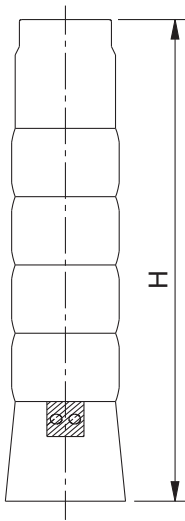

PUMP MODEL	HEIGHT (mm)	APPROX NETT. WEIGHT (kg)
8GS-78/01	554	21.94
8GS-78/02	682	25.61
8GS-78/03	810	29.25
8GS-78/04	938	32.88
8GS-78/05	1066	36.52
8GS-78/06	1194	40.87
8GS-78/07	1322	44.58
8GS-78/08	1450	48.30
8GS-78/09	1578	52.01
8GS-78/10	1706	55.72
8GS-78/11	1834	59.5
8GS-78/12	1962	63.15
8GS-78/13	2090	66.88
8GS-78/14	2218	70.582
8GS-78/15	2346	74.5
8GS-78/16	2474	78.012
8GS-78/17	2602	81.724
8GS-78/18	2730	85.446
8GS-78/19	2858	89.158
8GS-78/20	2986	92.864
8GS-78/21	3114	96.57
8GS-78/22	3242	100.28

PUMP MODEL	HEIGHT (mm)	APPROX NETT. WEIGHT (kg)
8GS-95/01	554	22.02
8GS-95/02	682	25.80
8GS-95/03	810	29.55
8GS-95/04	938	33.29
8GS-95/05	1066	37.03
8GS-95/06	1194	41.49
8GS-95/07	1322	45.32
8GS-95/08	1450	49.15
8GS-95/09	1578	52.96
8GS-95/10	1706	56.79
8GS-95/11	1834	60.61
8GS-95/12	1962	64.44
8GS-95/13	2090	68.28
8GS-95/14	2218	73.53
8GS-95/15	2346	75.90
8GS-95/16	2474	79.80
8GS-95/17	2602	83.80
8GS-95/18	2730	87.75
8GS-95/19	2858	91.67
8GS-95/20	2986	95.60
8GS-95/22	3242	104.01
8GS-95/24	3370	110.77

# 10" GS SERIES PUMPS

Nominal Diameter : 10"    Nominal Flow : 125 m<sup>3</sup>/h    Outlet Size : 6"

## PERFORMANCE CURVES

Flow Range : 40 - 162 m<sup>3</sup>/h

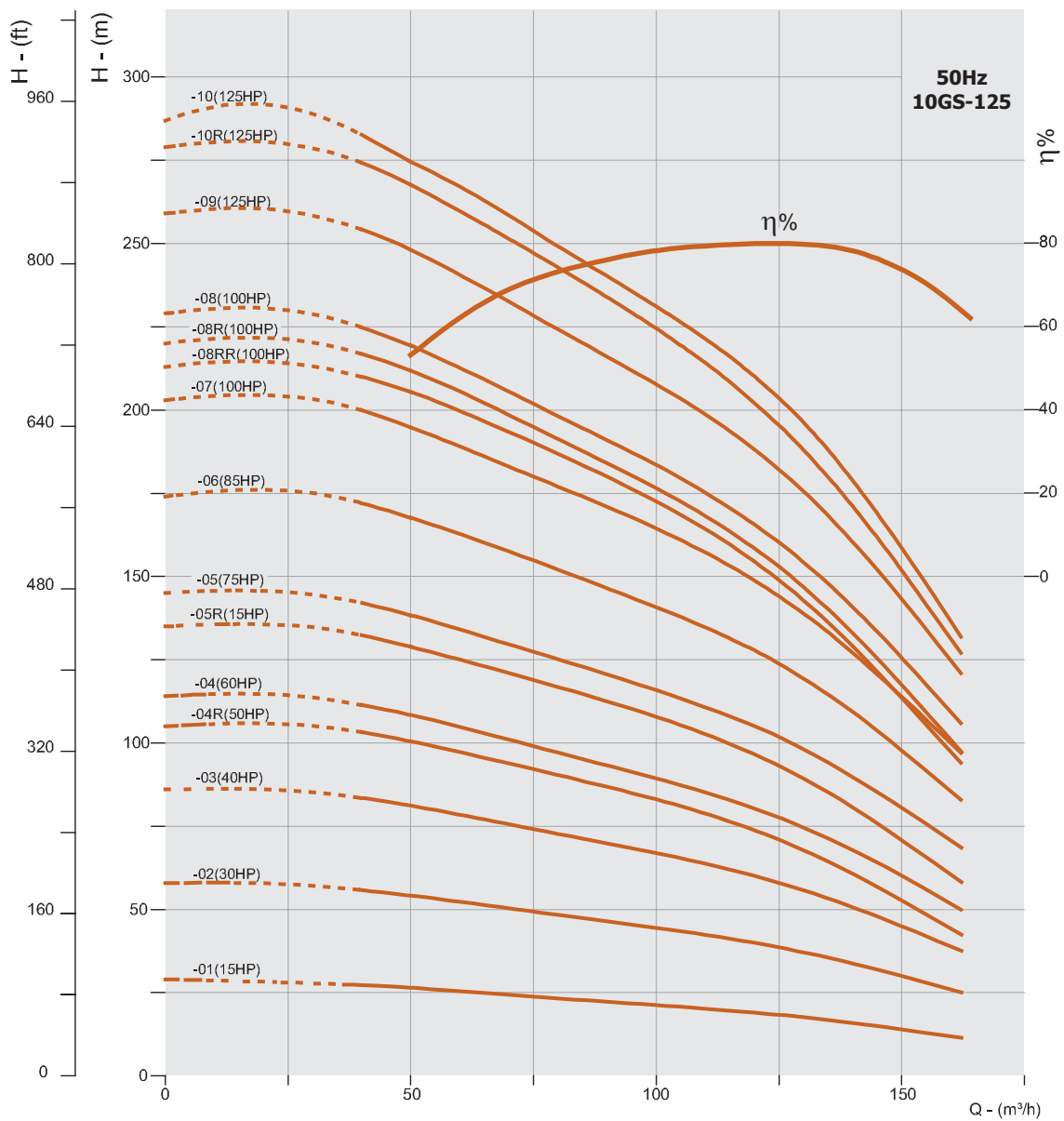

# 10" GS SERIES PUMPS

Nominal Diameter : 10" Nominal Flow : 125 m<sup>3</sup>/h Outlet Size : 6"

## PERFORMANCE CURVES

Flow Range : 40 - 162 m<sup>3</sup>/h

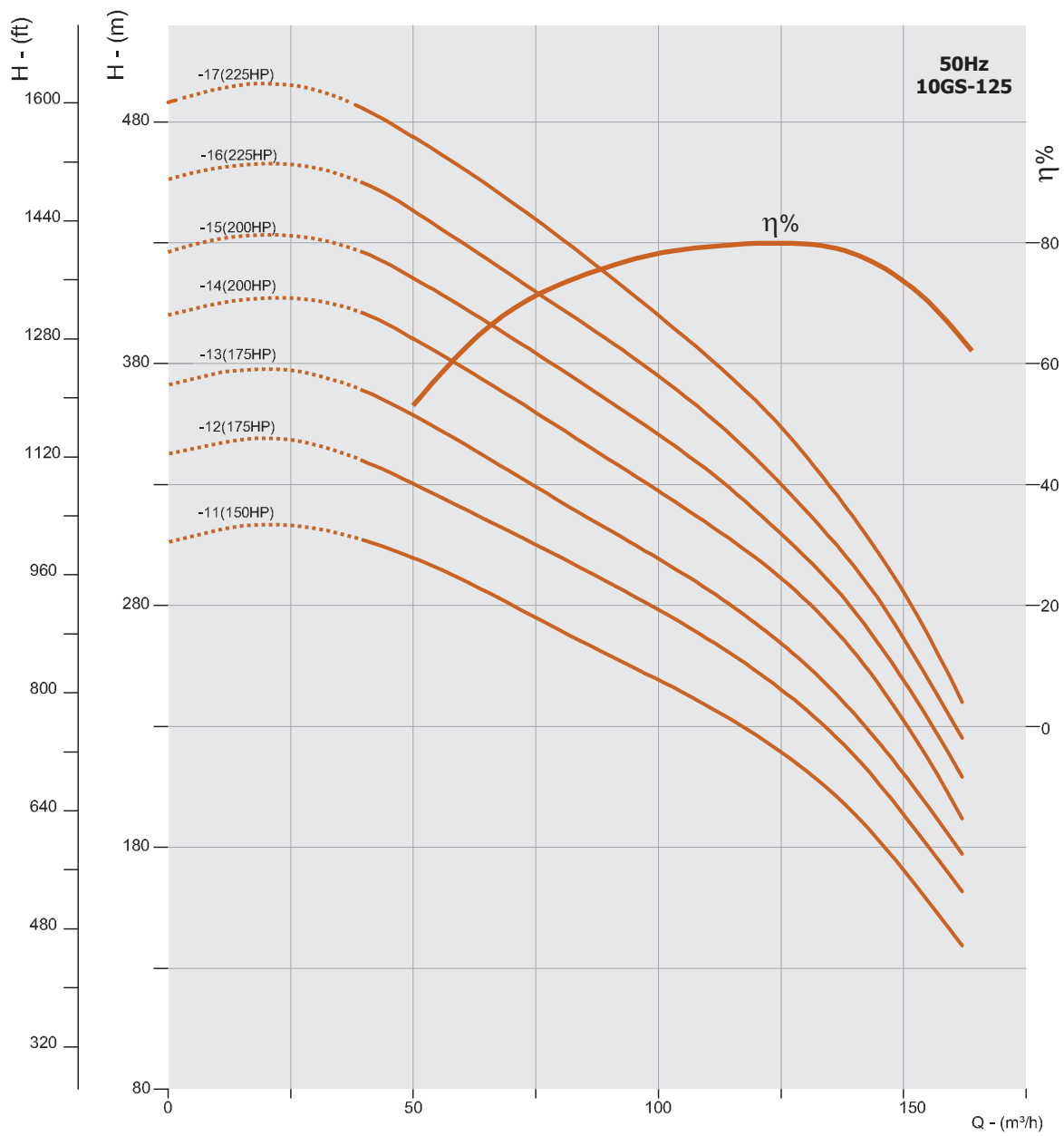

# 10" GS SERIES PUMPS

Nominal Diameter : 10"    Nominal Flow : 160 m<sup>3</sup>/h    Outlet Size : 6"

## PERFORMANCE CURVES

Flow Range : 50 - 200 m<sup>3</sup>/h

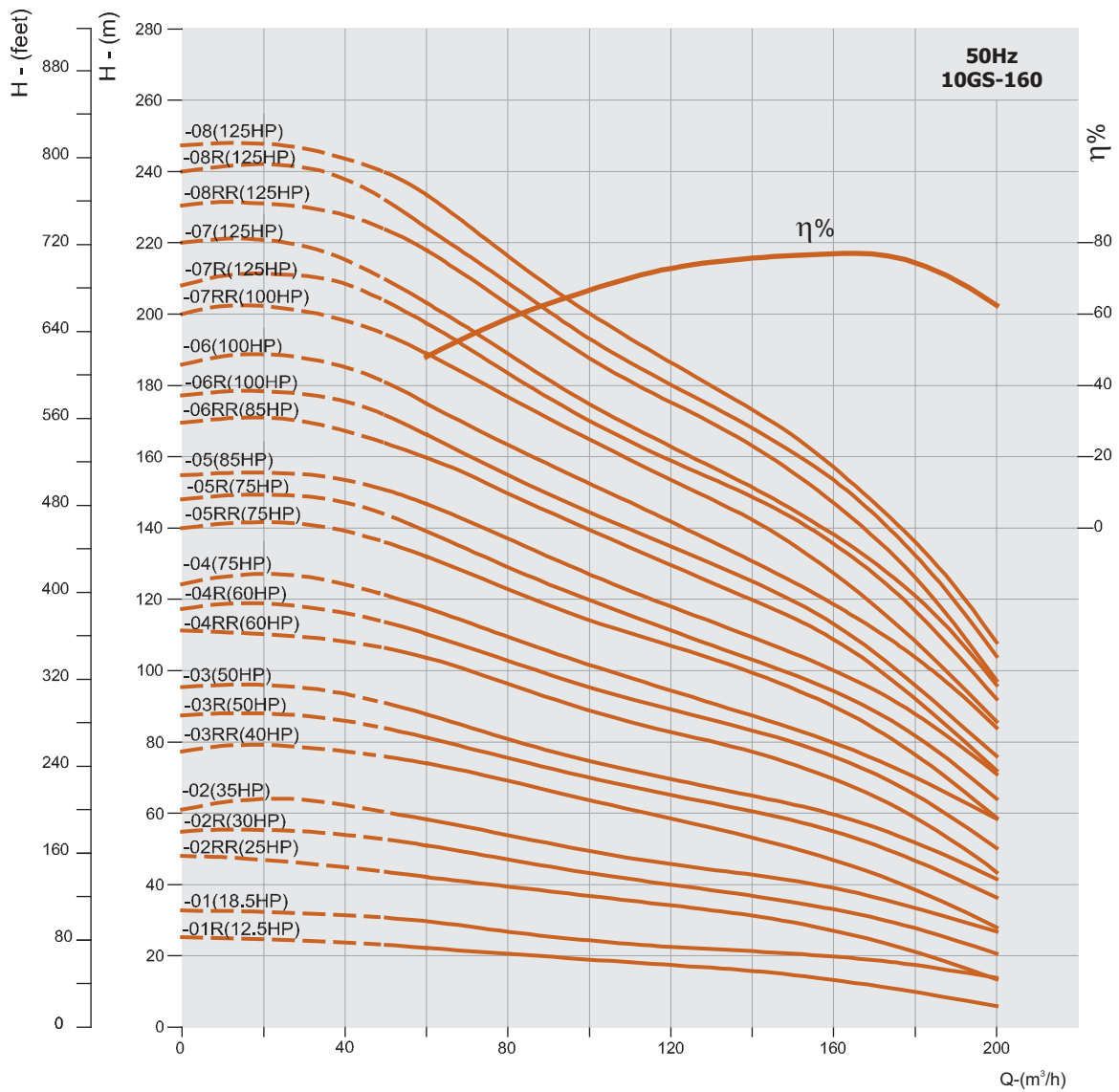

# 10" GS SERIES PUMPS

Nominal Diameter : 10" Nominal Flow : 160 m<sup>3</sup>/h Outlet Size : 6"

## PERFORMANCE CURVES

Flow Range : 50 - 200 m<sup>3</sup>/h

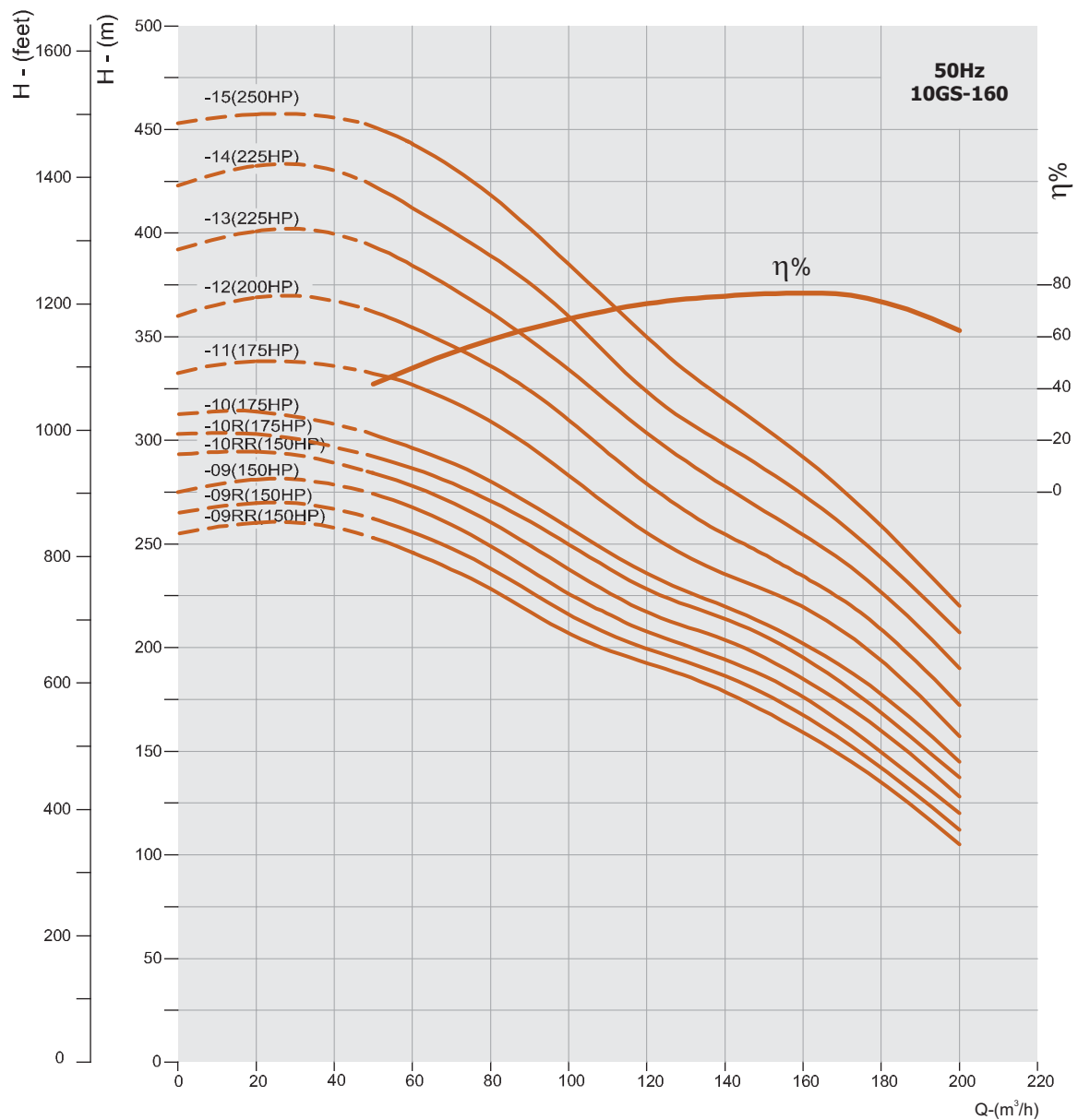

# 10" GS SERIES PUMPS

Nominal Diameter : 10"    Nominal Flow : 215 m<sup>3</sup>/h    Outlet Size : 6"

## PERFORMANCE CURVES

Flow Range : 63 - 280 m<sup>3</sup>/h

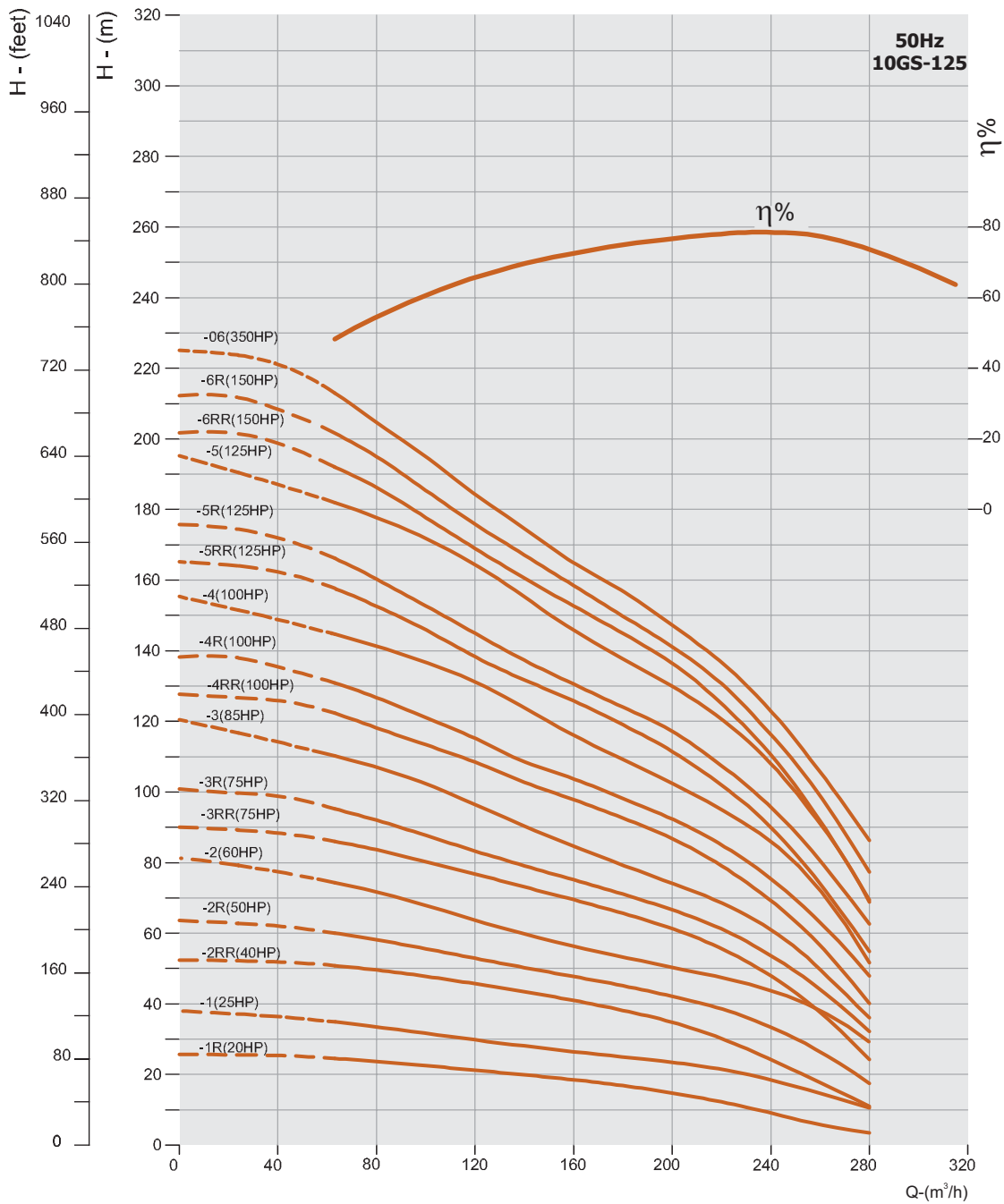



# 10" GS SERIES PUMPS

Nominal Diameter : 10"    Nominal Flow : 215 m<sup>3</sup>/h    Outlet Size : 6"

## PERFORMANCE CURVES

Flow Range : 63 - 280 m<sup>3</sup>/h

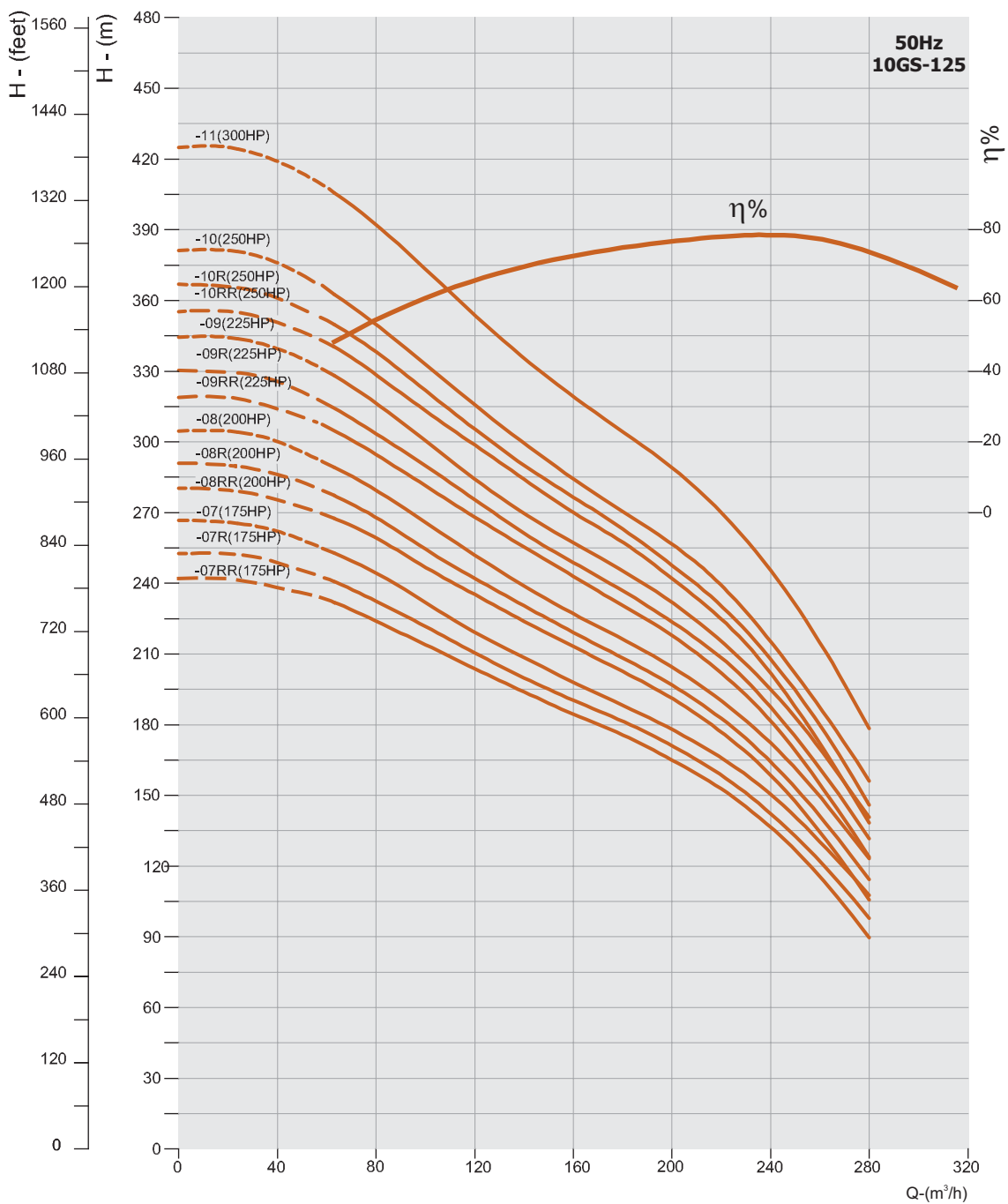

# 10" GS SERIES PUMPS

Nominal Diameter : 10"

## HEIGHT & WEIGHT TABLE

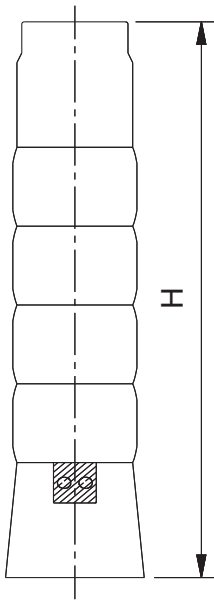

PUMP MODEL	HEIGHT (mm)	APPROX NETT. WEIGHT (kg)
10GS-125/01	644	30.62
10GS-125/02	798	36.77
10GS-125/03	952	42.91
10GS-125/04R	1106	49.05
10GS-125/04	1106	49.05
10GS-125/05R	1260	55.20
10GS-125/05	1260	55.20
10GS-125/06	1414	61.33
10GS-125/07	1568	67.48
10GS-125/08RR	1722	73.62
10GS-125/08R	1722	73.62
10GS-125/08	1722	73.62
10GS-125/09	1876	79.76
10GS-125/10R	2030	85.90
10GS-125/10	2030	85.90
10GS-125/11	2184	92.05
10GS-125/12	2338	98.19
10GS-125/13	2492	109.03
10GS-125/14	2646	119.87
10GS-125/15	2800	130.71
10GS-125/16	2954	141.55
10GS-125/17	3108	152.40

## 10" GS SERIES PUMPS

Nominal Diameter : 10"

### HEIGHT & WEIGHT TABLE

PUMP MODEL	HEIGHT (mm)	APPROX NETT. WEIGHT (kg)
10GS - 160/01R	646	30.24
10GS - 160/01	646	30.24
10GS - 160/02RR	802	36.47
10GS - 160/02R	802	36.47
10GS - 160/02	802	36.47
10GS - 160/03RR	958	42.71
10GS - 160/03R	958	42.71
10GS - 160/03	958	42.71
10GS - 160/04RR	1114	48.93
10GS - 160/04R	1114	48.93
10GS - 160/04	1114	48.93
10GS - 160/05RR	1270	55.65
10GS - 160/05R	1270	55.65
10GS - 160/05	1270	55.65
10GS - 160/06RR	1426	61.88
10GS - 160/06R	1426	61.88
10GS - 160/06	1426	61.88
10GS - 160/07RR	1582	68.09
10GS - 160/07R	1582	68.09
10GS - 160/07	1582	68.09
10GS - 160/08RR	1738	74.32
10GS - 160/08R	1738	74.32
10GS - 160/08	1738	74.32
10GS - 160/09RR	1894	83.49
10GS - 160/09R	1894	83.49
10GS - 160/09	1894	83.49
10GS - 160/10RR	2050	89.71
10GS - 160/10R	2050	89.71
10GS - 160/10	2050	89.71
10GS - 160/11	2206	95.92
10GS - 160/12	2362	106.54
10GS - 160/13	2518	112.75
10GS - 160/14	2674	118.98
10GS - 160/15	2830	125.19

PUMP MODEL	HEIGHT (mm)	APPROX NETT. WEIGHT (kg)
10GS - 215/1R	794	47.00
10GS - 215/1	794	47.00
10GS - 215/2RR	670	59.50
10GS - 215/2R	670	59.50
10GS - 215/2	670	59.50
10GS - 215/3RR	1146	79.50
10GS - 215/3R	1146	79.50
10GS - 215/3	1146	79.50
10GS - 215/4RR	1322	92.00
10GS - 215/4R	1322	92.00
10GS - 215/4	1322	92.00
10GS - 215/5RR	1498	104.50
10GS - 215/5R	1498	104.50
10GS - 215/5	1498	104.50
10GS - 215/6RR	1674	117.00
10GS - 215/6R	1674	117.00
10GS - 215/6	1674	117.00
10GS - 215/7RR	1850	129.50
10GS - 215/7R	1850	129.50
10GS - 215/7	1850	129.50
10GS - 215/8RR	2026	142.00
10GS - 215/8R	2026	142.00
10GS - 215/8	2026	142.00
10GS - 215/9RR	2202	154.50
10GS - 215/9R	2202	154.50
10GS - 215/9	2202	154.50
10GS - 215/10RR	2378	167.00
10GS - 215/10R	2378	167.00
10GS - 215/10	2378	167.00
10GS - 215/11	2554	179.50



# NOTES

A series of horizontal dotted lines for writing notes, spanning the width of the page.

# NOTES

A series of horizontal dotted lines for taking notes.



## Vision & Mission

To lead from the front and set the standard in providing fluid management solutions across a wide spectrum of industries across the globe. To make the world a better place by embracing viable, sustainable technologies and processes and enlightened business practices. Our experience, expertise, the quality of our people and, of course, our strong customer orientation would be factors that would leverage our efforts to achieve our ends and fulfil our avowed commitment to all our stakeholders.



Saravanampatti, Coimbatore,  
India - 641035.  
Email: [sales@gransaglobal.com](mailto:sales@gransaglobal.com)